



**MAXIM**  
Crane Works, L.P.  
1-877-MAX-LIFT

# TMS875

Carrier-mounted hydraulic crane

maximcrane.com

- 75 tons (68,000 kg) maximum capacity
- 178 ft. (54.3m) of tip height stowable on crane
- Maximum tip height of 206 ft. (63.1m)
- Choice of full power or power pinned boom

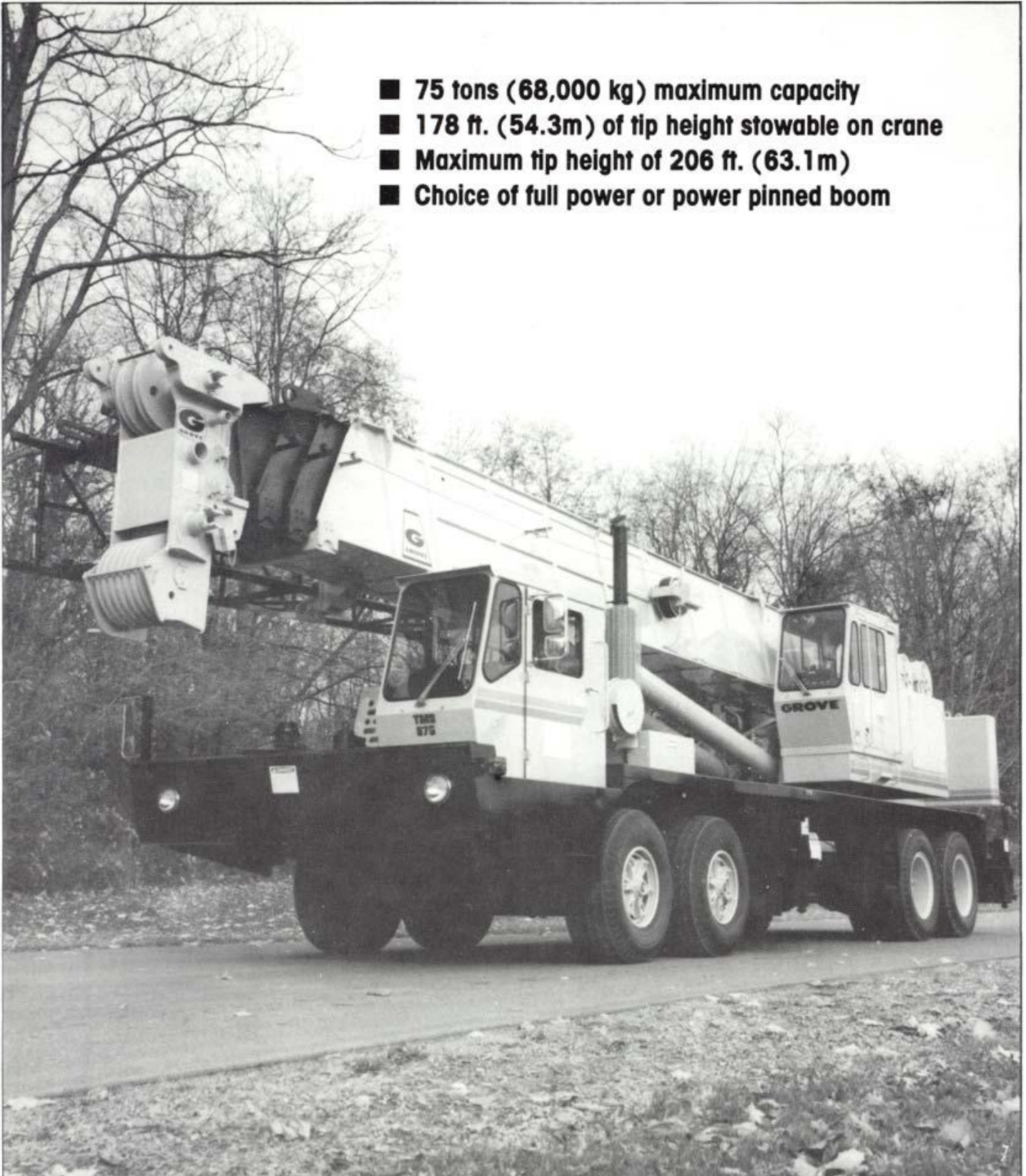

# Carrier specifications

<b>Frame</b>	High strength alloy steel all welded box-type construction with integral outrigger housings and front/rear lifting, towing and tie down lugs.
<b>Outrigger System</b>	Hydraulic single stage, double box telescopic beam and jack outriggers with integral holding valves. All steel fabricated quick release type outrigger floats 30.5" (775mm) diameter. Standard fifth front stabilizer for 360° duties.
<b>Outrigger Controls</b>	Located in superstructure cab and on both sides of the carrier frame. Push button controls requiring two-handed operation for safety. Crane level indicator (sight bubble) adjacent to controls.
<b>Engine</b>	GM6-71T six cylinder turbo-charged water cooled diesel, 426 cu. in. (7 L) 280 bhp (208 kw) (Gross) @ 2100 RPM. Maximum torque 785 ft. lbs. (109 kg/m) @ 1000 RPM.
<b>Optional Engine</b>	Cummins NTC300 six cylinder turbo-charged water cooled diesel 855 cu. in. (14 L) 300 bhp (224 kw) (Gross) @ 2100 RPM. Maximum net torque 1000 ft. lbs. (138 kg/m) @ 1300 RPM.
<b>Fuel Tank Capacity</b>	(1) 100 gallons (379 L)
<b>Electrical System</b>	Four 12 volt - maintenance free batteries, 24 volt starting.
<b>Drive</b>	8 x 4
<b>Steering</b>	Front axle steering, worm and roller type with hydraulic assist.
<b>Transmission</b>	Roadranger gearbox with 9 speeds forward and 2 reverse, with 2 speed auxiliary transmission.
<b>Optional Transmission</b>	Automatic, with 5 speeds forward, 1 reverse, with 2 speed auxiliary transmission.
<b>Axles</b>	Axles 1 & 2, steering, tubular steel, 100 in. track. Axles 3 & 4, single reduction drive, 100 in. track with inter-axle differential lock.
<b>Suspension</b>	Front axles (1 & 2) spring mounted tandem. Rear axles (3 & 4) solid mount tandem with equalizing beam.
<b>Tires</b>	Front: 18:00x22.5-18PR highway tread, tubeless. Rear: 12:00x24-16PR highway tread, tube type.

<b>Optional Tires</b>	Front: 14:00x20-22PR Michelin radial, tube type. Rear: 14.00x20-22PR Michelin radial tube type.
<b>Brakes</b>	Full air on all wheels. Air dryer provided to preclude moisture accumulation. Spring set emergency brake on both rear axles with emergency release.
<b>Lights</b>	Full lighting including head, tail, braking, reversing, directional and hazard warning lights.
<b>Cab</b>	One man design, all steel fabricated with acoustical lining and tinted safety glass throughout. Deluxe fabric covered fully adjustable seat. Complete driving controls and engine instrumentation including tachometer, speedometer, voltmeter, water temp. oil pressure, fuel level, air pressure gauge with A/V warning. Other standard items include hot water heater/defroster, electric windshield wash/wipe, fire extinguisher, seat belt and door and window locks.
<b>Maximum Speed</b>	47.8 MPH (76.9 kph)
	BASIC STANDARD MACHINE
<b>Gross Vehicle Weight &amp; Axle Loads</b>	Front Tandem: 36,380 lbs. (16,502 kgs) Rear Tandem: 64,596 lbs. (29,301 kgs) G.V.W.: 100,976 lbs. (45,803 kgs)
<b>Miscellaneous Standard Equipment</b>	Dual rear view mirrors, hookblock tiedown sling, electronic back-up alarm, light package.
<b>Optional Equipment</b>	Immersion engine block heater, engine low oil pressure/high water temperature, audio visual warning. Jacobs engine brake, back-up alarm, tire inflation kit.

<sup>†</sup>Patented Grove feature or patent pending.  
<sup>\*</sup>Denotes optional equipment.

# Superstructure specifications

<b>Boom</b>	36 ft. to 114 ft. (11m - 34.7m) four section Trapezoidal† power pinned or optional full power boom. Telescopic sections slide on adjustable and replaceable nylatron pads. Maximum tip height: 122 ft. (37.2m).
<b>Swingaway Extension</b>	33 ft. (10.1m) lattice swingaway boom extension stows alongside base boom section when not in use, offsettable at 2°, 15° or 30°. Maximum tip height: 155 ft. (47.2m).
<b>*Optional Telescopic Swingaway</b>	33 ft. to 58 ft. (17.7m) telescopic lattice swingaway extension with offset links, offsettable at 2°, 15° or 30°. Stows alongside base boom when not in use. Maximum tip height: 178 ft. (54.6m).
<b>Optional Jib Extension</b>	46 ft. (14m), 60 ft. (18.3m) 74 ft. (22.6m) and 88 ft. (26.8m) fixed offset jib. Maximum tip height: 206 ft. (62.8m).
<b>Boom Nose</b>	Six sheaves mounted on heavy duty tapered roller bearings with removable pin-type rope guards. *Optional removable auxiliary boom nose with removable pin type rope guard.
<b>Boom Elevation</b>	Two double acting hydraulic cylinders with integral holding valve provides elevation from -4° to 80°.
<b>Load Moment &amp; Anti-Two Block System</b>	Standard load moment and anti-two block system with audio-visual warning and control lever lockout to alert operator of impending two-block condition. Electronic display of boom angle, length, radius, tip height, relative load moment, maximum permissible load and actual load indication is provided.
<b>Cab</b>	Full vision, all steel fabricated with accoustical lining and tinted safety glass throughout. Dash panel incorporates gauges for all engine functions. Other standard features include: hinged skylight, sliding left side door and sliding right side window, electric windshield wash-wipe, circulating air fan, heater, swing horn, fire extinguisher, seat belt. *Optional items: electric skylight wiper and air conditioning.
<b>Swing</b>	Ball bearing swing circle with 360° continuous rotation. Grove planetary "glide swing" with foot actuated disc brake, spring applied hydraulically released park brake and 360° position positive turntable lock. Combination controls provided for hand or foot operation. Swing speed 1.8 RPM.
<b>Counterweight</b>	Fixed position pinned to turntable. *Power installation and removal system is available. Weight varies depending on hoist configuration

## HYDRAULIC SYSTEM

<b>Pumps</b>	Two tandem main gear pumps driven by carrier engine through PTO with manual disconnect. Combined capacity 178 GPM (674 LPM).
<b>Valves</b>	Precision four way double acting control valves, 4 individual valve banks permit simultaneous control of multiple crane functions.
<b>Filter</b>	Suction line type, full flow with by-pass protection and filter by-pass indicator, replaceable cartridge, 7/17/22 micron filtration rating.
<b>Reservoir</b>	260 gallons (984 L) with spin-on breather filter, external sight gauge, clean out access, strap mounted to frame.
<b>Oil Cooler</b>	Full flow, fin and tube, oil to air.

## HOIST SPECIFICATIONS

Series parallel circuitry and two motors provide both high line pull and speed ranges. Power up and down, equal speed, planetary reduction with integral automatic brake and electronic hoist drum rotation indicator.

Make/Model		Grove Main Hoist H030B-26(H) or *Auxiliary Hoist H030B-26(H)	
		High Range	Low Range
<b>Maximum single line speed</b>	Bottom layer	454 FPM (138m/min)	227 FPM (69m/min)
	Intermediate layer	528 FPM (161m/min)	264 FPM (80m/min)
	Top layer	602 FPM (183m/min)	301 FPM (92m/min)
<b>Maximum single line pull</b>	Bottom layer	8,161 lbs. (3702 kg)	16,322 lbs. (7404 kg)
	Intermediate layer	7,028 lbs. (3188 kg)	14,056 lbs. (6376 kg)
	Top layer	6,172 lbs. (2800 kg)	12,344 lbs. (5599 kg)
<b>Maximum permissible line pull w/5:1 Strength Factor</b>		Main 14,720 lbs. (6677 kg)	Aux. 12,920 lbs. (5875 kg)
	<b>Maximum rope stowage</b>	Auxiliary 650 ft. of 3/4 in. dia. rope (198m of 19mm)	

†Patented Grove feature or patent pending.  
\*Denotes optional equipment.

# Dimensions

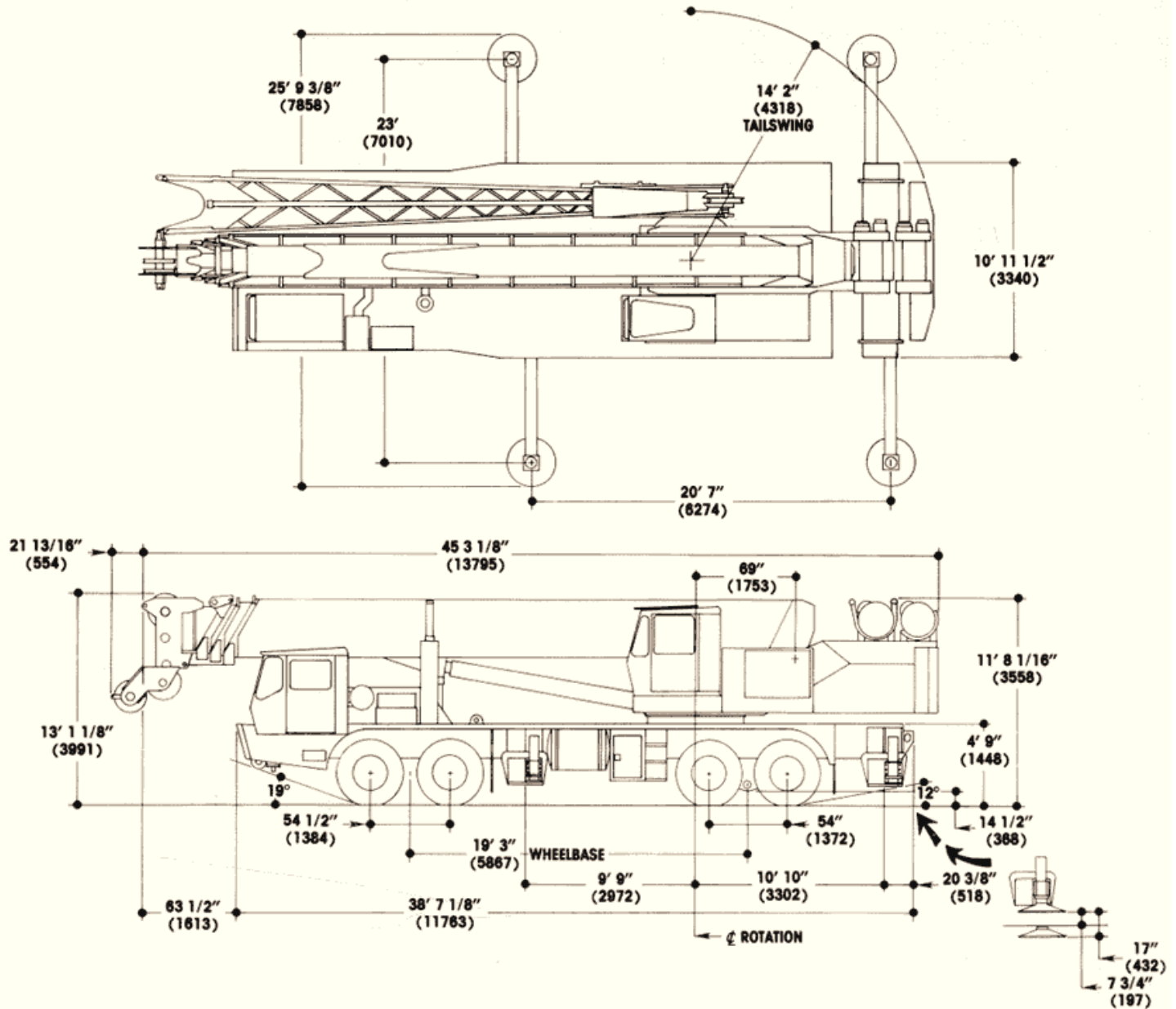

Distributed By

Constant improvement and engineering progress makes it necessary that we reserve the right to make specification, equipment, and price changes without notice. Illustrations shown may include optional equipment and accessories and may not include all standard equipment.

North and South America, Far East, Australasia

**GROVE MANUFACTURING COMPANY**

Box 21 • Shady Grove • Pennsylvania 17256  
 (717) 597-8121 • telex: 842308 • fax: (717) 597-4062

Europe, Africa, Middle East, Indian Sub-continent

**GROVE**

Telford Rd. • Bicester • Oxfordshire OX6 0TZ  
 (0869) 246800 • telex: 837447 • fax: 0869-246965



# TMS875

## AXLE WEIGHT DISTRIBUTION CHART

	POUNDS			KILOGRAMS		
	GROSS	FRONT	REAR	GROSS	FRONT	REAR
Basic standard unit including 36-114 ft. (11-34.7m) trapezoidal boom, 33 ft. (10m) offsettable swingaway, Grove model HO30B-26 main hoist with 650 ft. (198m) of 3/4 in. (19mm) diameter rope, fifth outrigger jack, GM6-71T diesel engine, Fuller transmission, 18:00 tires front and 12:00 tires rear and standard counterweight.	100,975	36,380	64,595	45,803	16,502	29,301
<b>SUBSTITUTE</b>						
33-58 ft. (10-17.7m) Telescoping Offsettable Swingaway	+1,024	+882	+142	+464	+400	+64
Cummins NTC300 Engine	+500	+517	-17	+227	+235	-8
Caterpillar 3306TA Engine	+50	+52	-2	+23	+24	-1
36-114 ft. (11-34.7m) Full Power Boom	+2,559	+1,459	+1,100	+1,161	+662	+499
<b>ADDITIONS</b>						
Model HO30B-16 Auxiliary Hoist with Wire Rope (includes counterweight sub.)	+830	-404	+1,234	+376	-183	+559
Auxiliary Boom Nose	+230	+409	-179	+104	+185	-81
80 Ton Hookblock (stowed)	+1,930	+2,506	-576	+875	+1,137	-262
<b>REMOVE</b>						
10,500 lb. (4763 kg) Counterweight	-10,500	+5,500	-16,000	-4,763	+2,995	-7,258
8,800 lb. (3992 kg) Counterweight - use when equipped with auxiliary hoist	-8,800	+4,630	-13,430	-3,992	+2,100	-6,092
33 ft. (10m) Offsettable Swingaway	-2,679	-2,193	-486	-1,215	-995	-220

Constant improvement and engineering progress makes it necessary that we reserve the right to make specification, equipment, and price changes without notice. Illustrations shown may include optional equipment and accessories and may not include all standard equipment.



# TMS875

85% Domestic/36 ft.-114 ft. Power Pinned Boom

RANGE DIAGRAM (UNLADEN BOOM)

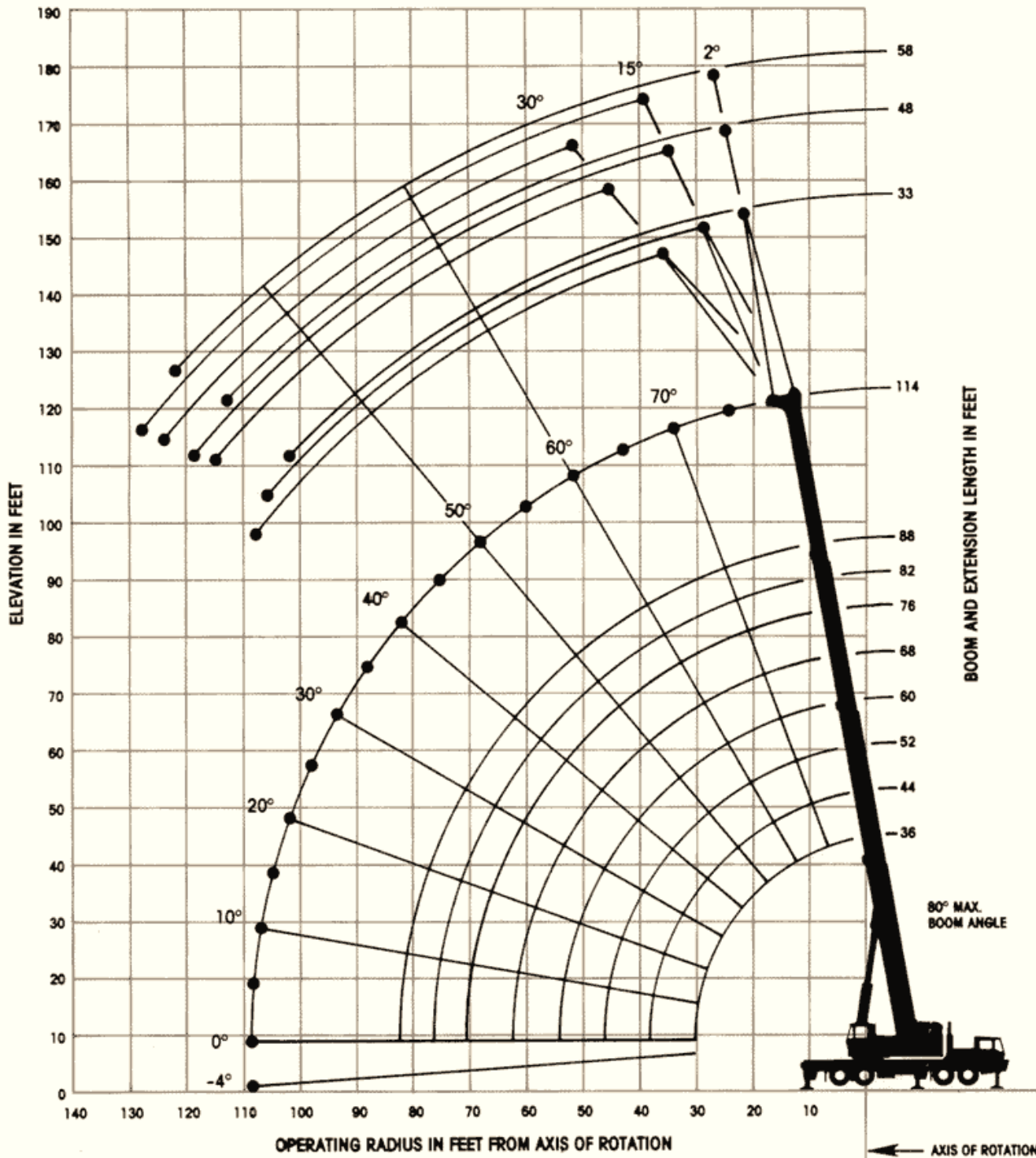

**RATED LIFTING CAPACITIES IN POUNDS  
POWER PINNED BOOM  
(ON OUTRIGGERS - 360°)**

Radius in Feet	Main Boom Length in Feet (Power Pinned Fly Retracted)								Power Pin. Fly Ext. 88 ft.
	36	44	52	60	68	76	82	88	
10	150,000 (67)	106,700 (71.5)	101,600 (74.5)	100,000 (77)	96,700 (79)				
12	123,500 (63)	106,700 (68.5)	101,600 (72)	96,500 (75)	87,850 (77)	84,700 (78.5)			
15	105,000 (57.5)	105,000 (64)	95,300 (68.5)	84,900 (72)	79,200 (74.5)	77,550 (76)	70,250 (77.5)	64,500 (79)	
20	78,850 (47)	78,850 (56.5)	78,850 (62.5)	70,550 (66.5)	64,350 (70)	63,800 (72)	59,400 (74)	55,000 (75.5)	38,750 (80)
25	60,000 (34)	60,000 (48)	60,000 (55.5)	60,000 (61)	54,000 (65.5)	49,700 (67.5)	47,150 (70.5)	45,600 (72)	34,000 (77)
30		46,150 (38)	46,150 (48.5)	46,150 (55.5)	46,150 (60.5)	42,750 (63.5)	40,450 (66.5)	39,150 (68.5)	30,300 (74.5)
35		33,850 (24.5)	33,850 (40.5)	33,850 (49.5)	33,850 (55.5)	33,850 (58.5)	33,850 (62.5)	33,850 (65)	27,250 (71.5)
40			25,900 (30.5)	25,900 (42.5)	25,900 (50)	25,900 (54)	25,900 (58.5)	25,900 (61.5)	24,750 (69)
45			20,300 (14.5)	20,300 (34.5)	20,300 (44)	20,300 (49)	20,300 (54)	20,300 (57.5)	22,650 (66)
50				16,200 (24)	16,200 (37.5)	16,200 (43.5)	16,200 (49.5)	16,200 (53.5)	19,400 (63)
60					10,500 (17.5)	10,500 (30.5)	10,500 (39)	10,500 (44)	13,350 (57)
70							6,740 (24.5)	6,740 (33)	9,420 (50.5)
80								4,090 (14)	6,610 (43)
90									4,510 (34.5)
100									2,890 (23)
Minimum boom angle (deg.) for indicated length (no load)									0
Maximum boom length (ft.) at 0 deg. boom angle (no load)									88

Note: Boom angles are in degrees.

A6-829-008818

**CAPACITIES FOR 33 FT. - 58 FT. TELE. EXTENSION (ON OUTRIGGERS - 360°)**

Main Boom Angle (Deg.)	33 ft. LENGTH						48 ft. LENGTH						58 ft. LENGTH					
	2° OFFSET		15° OFFSET		30° OFFSET		2° OFFSET		15° OFFSET		30° OFFSET		2° OFFSET		15° OFFSET		30° OFFSET	
	Rad. Ref. ft.	Cap. lbs.	Rad. Ref. ft.	Cap. lbs.	Rad. Ref. ft.	Cap. lbs.	Rad. Ref. ft.	Cap. lbs.	Rad. Ref. ft.	Cap. lbs.	Rad. Ref. ft.	Cap. lbs.	Rad. Ref. ft.	Cap. lbs.	Rad. Ref. ft.	Cap. lbs.	Rad. Ref. ft.	Cap. lbs.
<b>POWER PINNED FLY RETRACTED</b>																		
80	18.6	30,000	25.4	20,000	32.5	15,000	22.5	20,000	32.6	12,000	42.8	10,000	27.0	16,000	38.4	10,000	50.1	7,800
75	28.8	25,600	35.2	18,000	41.8	13,300	34.0	16,500	43.5	10,000	53.0	8,100	39.3	13,200	50.1	9,000	61.0	6,600
70	38.7	21,500	44.8	16,000	50.8	12,000	45.2	14,000	54.2	8,800	62.9	7,000	51.3	11,000	61.5	8,000	71.4	6,000
65	48.4	17,800	54.0	14,000	59.4	11,200	56.0	11,800	64.4	7,800	72.3	6,600	62.9	9,500	72.3	7,200	81.4	5,500
60	57.6	14,200	62.8	11,500	67.4	9,540	66.4	10,300	74.1	7,100	81.0	6,200	74.0	8,600	82.7	6,400	90.7	5,200
55	66.4	9,950	71.1	8,210	75.0	6,940	76.2	8,420	83.2	6,500	89.2	5,130	84.6	7,250	92.4	5,490	99.4	4,210
50	74.7	7,040	78.8	5,860	81.9	5,040	85.5	5,950	91.6	4,620	96.6	3,700	94.6	5,070	101.5	3,850	107.3	2,960
45	82.3	4,940	85.9	4,130	88.2	3,620	94.1	4,150	99.4	3,220	103.3	2,610	103.9	3,470	109.8	2,600	114.4	2,010
<b>POWER PINNED FLY EXTENDED</b>																		
80	25.5	22,500	31.9	15,150	38.6	10,950	29.9	15,500	39.5	10,000	48.9	7,140	33.2	10,300	44.4	7,780	55.9	5,530
75	37.8	16,700	43.9	11,600	50.1	8,890	43.3	11,250	52.5	7,840	61.4	5,890	47.8	8,840	58.1	6,130	68.9	4,590
70	49.8	13,750	55.6	9,240	61.2	7,400	56.5	8,530	65.3	6,300	73.5	4,950	61.4	6,760	71.5	4,960	81.5	3,870
65	61.5	11,100	66.9	7,560	71.9	6,270	69.2	6,720	77.5	5,190	85.0	4,220	75.0	5,350	84.3	4,100	93.4	3,300
60	72.6	8,970	77.7	6,320	82.0	5,400	81.4	5,440	89.1	4,350	95.8	3,640	87.9	4,340	96.4	3,440	104.6	2,860
55	83.2	5,870	87.9	4,780	91.4	4,040	93.0	4,500	100.1	3,700	105.8	3,060	100.2	3,590	107.9	2,920	114.9	2,450
50	93.2	3,680	97.3	2,920	100.1	2,450	103.8	3,340	110.2	2,470	115.1	1,880	111.8	2,040	118.5	2,040	124.4	1,410
45	102.4	2,080	106.1	1,540	108.1	1,260	113.9	2,020	119.6	1,390			122.5	1,610	128.1	1,040		

**CAPACITIES FOR 33 FT. - 58 FT. TELE. EXTENSION  
(ON OUTRIGGERS - 360°)**

Main Boom Angle (Deg.)	2° OFFSET		15° OFFSET		30° OFFSET	
	Rad. Ref. ft.	Cap. lbs.	Rad. Ref. ft.	Cap. lbs.	Rad. Ref. ft.	Cap. lbs.
<b>POWER PINNED FLY RETRACTED</b>						
80	18.6	30,000	25.4	20,500	32.5	15,500
75	28.8	26,100	35.2	18,500	41.8	13,800
70	38.7	22,000	44.8	16,500	50.8	12,500
65	48.4	18,300	54.0	14,500	59.4	11,700
60	57.6	14,850	62.8	12,200	67.4	10,150
55	66.4	10,650	71.1	8,890	75.0	7,600
50	74.7	7,750	78.8	6,550	81.9	5,720
45	82.3	5,660	85.9	4,820	88.2	4,310
<b>POWER PINNED FLY EXTENDED</b>						
80	25.5	23,000	31.9	15,650	38.6	11,450
75	37.8	17,200	43.9	12,100	50.1	9,390
70	49.8	14,250	55.6	9,740	61.2	7,900
65	61.5	11,600	66.9	8,060	71.9	6,770
60	72.6	9,600	77.7	6,820	82.0	5,900
55	83.2	6,610	87.9	5,500	91.4	4,740
50	93.2	4,430	97.3	3,650	100.1	3,170
45	102.4	2,830	106.1	2,280	108.1	1,990

A6-829-008477 & -008484

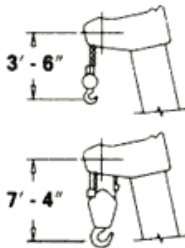

DIMENSIONS ARE FOR LARGEST GROVE FURNISHED HOOK BLOCK AND HEADACHE BALL, WITH ANTI-TWO BLOCK ACTIVATED.

**WEIGHT REDUCTIONS FOR LOAD HANDLING DEVICES**

33 FT. EXTENSION WITH 36 FT.-114 FT. BOOM	
†Stowed -	673 lbs.
†Erected -	6,243 lbs.
33 FT.-58 FT. TELE. EXTENSION WITH 36 FT.-114 FT. BOOM	
†Stowed -	926 lbs.
†Erected (ret.) -	9,322 lbs.
†Erected (ext.) -	12,860 lbs.

†Reduction of main boom capacities.

<b>HOOKBLOCKS:</b>	
15 Ton, 1 Sheave	650 lbs.
80 Ton, 6 Sheave	1,930 lbs.
Auxiliary Boom Head	230 lbs.
10 Ton Headache Ball	560 lbs.
7 1/2 Ton Headache Ball	338 lbs.

# NOTES FOR LIFTING CAPACITIES

1. All rated loads have been tested to and meet minimum requirements of SAE J1063 OCT80 - Cantilevered Boom Crane Structures - Method of Test, and do not exceed 85% of the tipping load on outriggers (75% of the tipping load on rubber) as determined by SAE J765 OCT80 Crane Stability Test Code.
2. This chart is intended as a guide only. The individual crane's load chart operating instructions and other instruction plates give details of the conditions under which the crane may be operated. ALL OF THESE INSTRUCTIONS MUST BE READ AND UNDERSTOOD PRIOR TO OPERATING THE CRANE.
3. Capacities given do not include the weight of hookblocks, slings, auxiliary lifting equipment and load handling devices. Their weights MUST be added to the load to be lifted. When more than minimum required reeving is used, the additional rope weight shall be considered part of the load.
4. Capacities appearing above the bold line are based on structural strength and tipping should not be relied upon as a capacity limitation.
5. All capacities are for crane on firm, level surface. It may be necessary to have structural supports under the outrigger floats or tires to spread the load to a larger bearing surface.
6. When either boom length or radius or both are between values listed, the smallest load shown at either the next larger radius or boom length shall be used.
7. For outrigger operation, ALL outriggers shall be fully extended with tires raised free of ground before raising the boom or lifting loads.
8. Tires shall be inflated to the recommended pressure before lifting on rubber.
9. Unless otherwise stated, capacities are with powered boom sections equally extended.

Constant improvement and engineering progress makes it necessary that we reserve the right to make specification, equipment, and price changes without notice. Illustrations shown may include optional equipment and accessories and may not include all standard equipment.

North and South America, Far East, Australasia

**GROVE MANUFACTURING COMPANY**

Box 21 • Shady Grove • Pennsylvania 17256  
(717) 597-8121 • telex: 842308 • fax: (717) 597-4062

Europe, Africa, Middle East, Indian Sub-continent

**GROVE**

Telford Rd. • Bicester • Oxfordshire OX6 0TZ  
(0869) 246800 • telex: 837447 • fax: 0869-246965





MAXIM  
CRANE WORKS  
T-877-MAX-LIFT

# TMS875

85% Domestic/36 ft.-114 ft. Full Power Boom

maximcrane.com

RANGE DIAGRAM (UNLADEN BOOM)

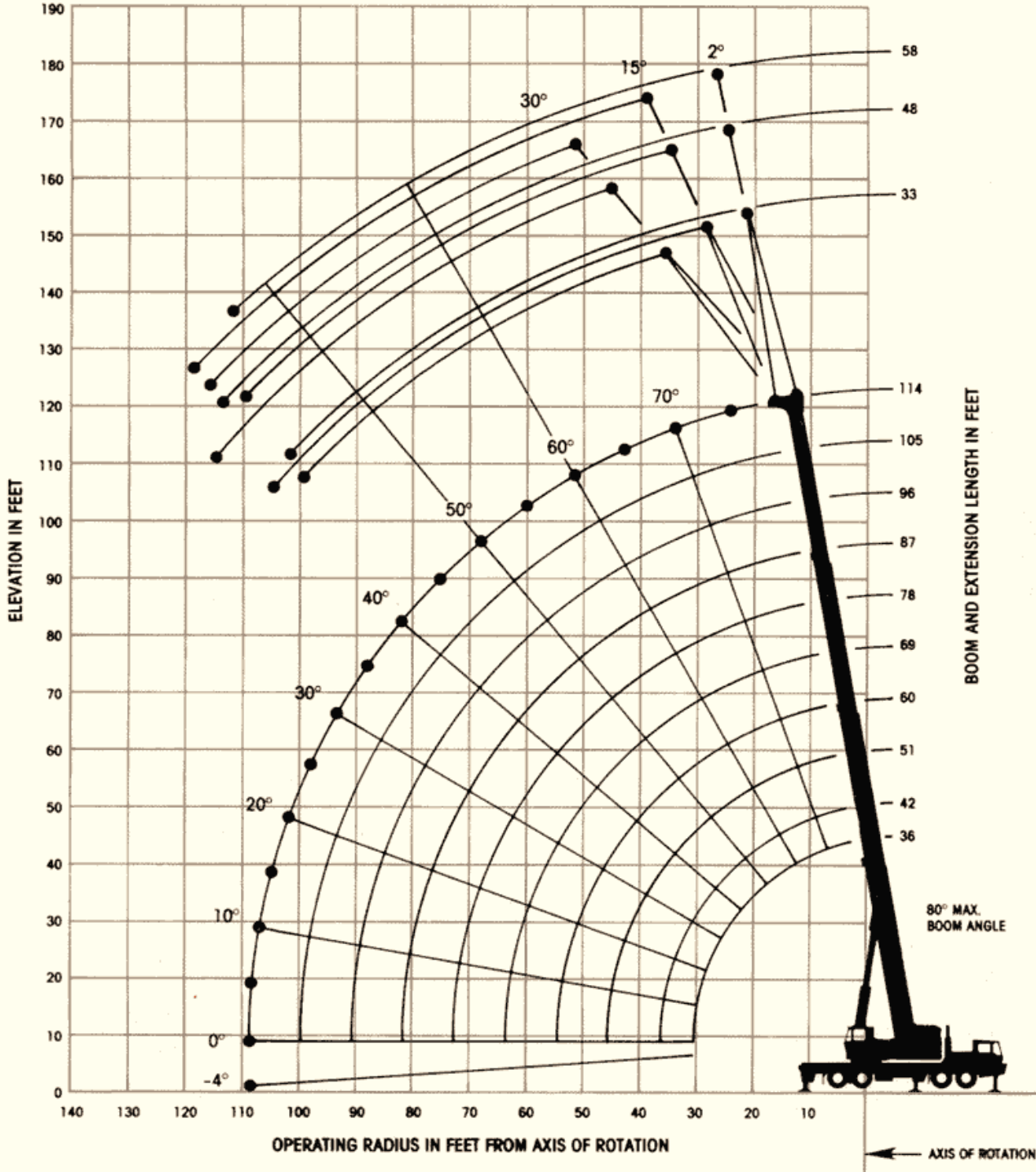



**CAPACITIES FOR 33 FT. FIXED LENGTH EXTENSION  
(ON OUTRIGGERS - 360°)**

Main Boom Angle (Deg.)	2° OFFSET		15° OFFSET		30° OFFSET	
	Rad. Ref. ft.	Cap. lbs.	Rad. Ref. ft.	Cap. lbs.	Rad. Ref. ft.	Cap. lbs.
80	27.0	23,000	32.9	15,650	39.2	11,450
75	39.2	17,200	44.8	12,100	50.6	9,390
70	51.0	14,250	56.2	9,740	61.6	7,900
65	62.5	11,600	67.3	8,060	72.1	6,770
60	73.5	8,700	77.8	6,820	82.0	5,900
55	83.9	5,860	87.7	4,990	91.3	4,250
50	93.7	3,840	96.9	3,260	99.9	2,770
45	102.8	2,360	105.4	1,970	107.7	1,660

A6-829-008492A

# NOTES FOR LIFTING CAPACITIES

1. All rated loads have been tested to and meet minimum requirements of SAE J1063 OCT80 - Cantilevered Boom Crane Structures - Method of Test, and do not exceed 85% of the tipping load on outriggers (75% of the tipping load on rubber) as determined by SAE J765 OCT80 Crane Stability Test Code.
2. This chart is intended as a guide only. The individual crane's load chart operating instructions and other instruction plates give details of the conditions under which the crane may be operated. ALL OF THESE INSTRUCTIONS MUST BE READ AND UNDERSTOOD PRIOR TO OPERATING THE CRANE.
3. Capacities given do not include the weight of hookblocks, slings, auxiliary lifting equipment and load handling devices. Their weights MUST be added to the load to be lifted. When more than minimum required reeving is used, the additional rope weight shall be considered part of the load.
4. Capacities appearing above the bold line are based on structural strength and tipping should not be relied upon as a capacity limitation.
5. All capacities are for crane on firm, level surface. It may be necessary to have structural supports under the outrigger floats or tires to spread the load to a larger bearing surface.
6. When either boom length or radius or both are between values listed, the smallest load shown at either the next larger radius or boom length shall be used.
7. For outrigger operation, ALL outriggers shall be fully extended with tires raised free of ground before raising the boom or lifting loads.
8. Tires shall be inflated to the recommended pressure before lifting on rubber.
9. Unless otherwise stated, capacities are with powered boom sections equally extended.

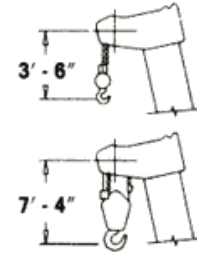

DIMENSIONS ARE FOR LARGEST GROVE FURNISHED HOOK BLOCK AND HEADACHE BALL WITH ANTI-TWO BLOCK ACTIVATED.

### WEIGHT REDUCTIONS FOR LOAD HANDLING DEVICES

33 FT. EXTENSION WITH 36 FT.-114 FT. BOOM	
†Stowed -	673 lbs.
†Erected -	6,243 lbs.
33 FT.-58 FT. TELE. EXTENSION WITH 36 FT.-114 FT. BOOM	
†Stowed -	926 lbs.
†Erected (ret.) -	9,322 lbs.
†Erected (ext.) -	12,860 lbs.

†Reduction of main boom capacities.

HOOKBLOCKS:	
15 Ton, 1 Sheave	650 lbs.
80 Ton, 6 Sheave	1,930 lbs.
Auxiliary Boom Head	230 lbs.
10 Ton Headache Ball	560 lbs.
7 1/2 Ton Headache Ball	338 lbs.

Constant Improvement and engineering progress makes it necessary that we reserve the right to make specification, equipment, and price changes without notice. Illustrations shown may include optional equipment and accessories and may not include all standard equipment.

North and South America, Far East, Australasia

**GROVE MANUFACTURING COMPANY**

Box 21 • Shady Grove • Pennsylvania 17256  
(717) 597-8121 • telex: 842308 • fax: (717) 597-4062

Europe, Africa, Middle East, Indian Sub-continent

**GROVE**

Telford Rd. • Bicester • Oxfordshire OX6 0TZ  
(0869) 246800 • telex: 837447 • fax: 0869-246965



# TMS875

MAXIM  
1-877-MAX-CRANE

85% Domestic/36 ft.-114 ft. Full Power & Power Pinned Boom

maximcrane.com

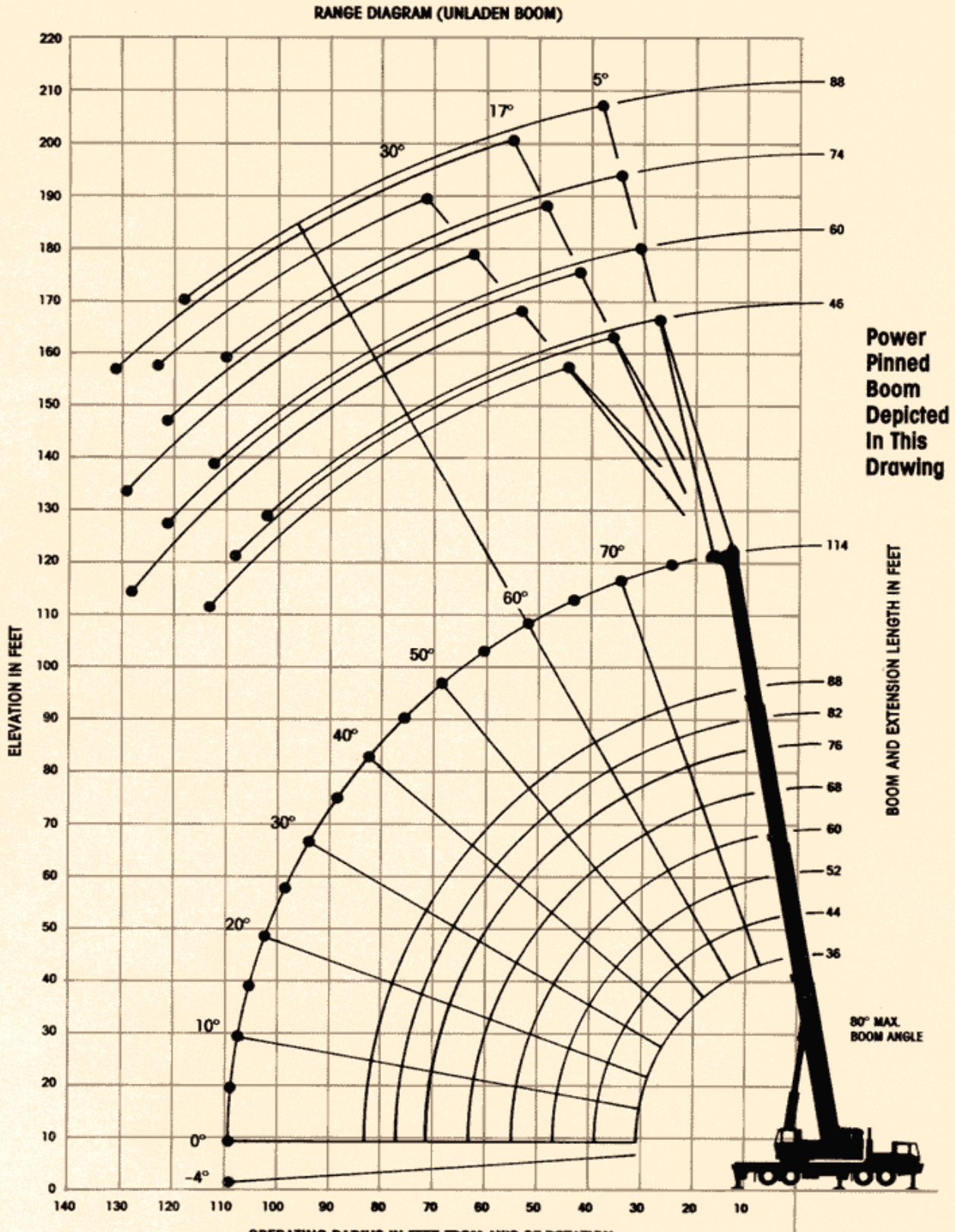



# TMS875



85% Domestic/36 ft.-114 ft. Full Power & Power Pinned Boom

maximcrane.com

## 88 FT. FIXED OFFSET JIBS ON OUTRIGGERS - 360° WITH COUNTERWEIGHT

Main Boom Angle (Deg.)	46 ft. JIB						60 ft. JIB					
	5° OFFSET		17° OFFSET		30° OFFSET		5° OFFSET		17° OFFSET		30° OFFSET	
	Rad. Ref. ft.	Cap. lbs.**	Rad. Ref. ft.	Cap. lbs.	Rad. Ref. ft.	Cap. lbs.	Rad. Ref. ft.	Cap. lbs.	Rad. Ref. ft.	Cap. lbs.	Rad. Ref. ft.	Cap. lbs.
80	32.0	14,000	41.0	11,950	49.0	8,480	36.3	10,600	48.2	8,160	58.0	5,680
77.5	38.4	13,350	47.2	11,550	55.2	8,080	43.3	9,970	54.5	7,790	64.7	5,320
75	44.9	12,800	53.2	11,150	61.2	7,690	50.3	9,490	60.9	7,450	71.3	5,020
72.5	51.2	12,250	59.6	10,300	67.2	7,350	57.2	8,930	67.5	7,130	77.8	4,760
70	57.5	9,930	65.4	8,390	72.9	7,020	63.9	8,380	74.1	6,830	84.2	4,540
67.5	63.7	7,970	71.4	6,870	78.6	6,100	70.6	6,710	80.6	5,610	90.3	4,340
65	69.7	6,450	77.2	5,640	84.1	5,080	77.1	5,380	86.8	4,580	96.3	4,030
62.5	75.6	5,240	82.8	4,640	89.5	4,220	83.4	4,320	92.7	3,730	102.1	3,310
60	81.3	4,250	88.2	3,800	94.7	3,490	89.6	3,460	98.6	3,010	107.8	2,700
55	92.4	2,750	99.0	2,490	104.4	2,320	101.4	2,130	110.0	1,870	118.3	1,700
50	102.7	1,660	108.2	1,520	113.4	1,420	112.5	1,160	121.9	1,010	128.1	920

Main Boom Angle (Deg.)	74 ft. JIB						88 ft. JIB					
	5° OFFSET		17° OFFSET		30° OFFSET		5° OFFSET		17° OFFSET		30° OFFSET	
	Rad. Ref. ft.	Cap. lbs.**	Rad. Ref. ft.	Cap. lbs.	Rad. Ref. ft.	Cap. lbs.	Rad. Ref. ft.	Cap. lbs.**	Rad. Ref. ft.	Cap. lbs.	Rad. Ref. ft.	Cap. lbs.
80	39.8	8,160	53.7	5,840	67.2	4,140	44.2	6,310	59.4	4,050	76.7	2,510
77.5	47.5	7,620	60.8	5,480	74.2	3,860	52.2	5,750	67.2	3,690	83.9	2,290
75	55.1	7,090	67.8	5,150	81.2	3,600	60.2	5,250	75.2	3,380	91.1	2,090
72.5	62.6	6,620	75.6	4,850	87.9	3,390	68.1	4,790	83.5	3,100	98.0	1,920
70	69.9	6,200	82.5	4,570	94.5	3,190	75.8	4,370	90.6	2,820	104.8	1,750
67.5	77.2	5,670	89.5	4,320	100.8	3,020	83.4	3,990	97.7	2,570	114.3	1,610
65	84.2	4,500	95.8	3,730	107.1	2,870	90.9	3,660	105.0	2,340	117.7	1,480
62.5	91.2	3,560	102.5	2,970	113.0	2,590	98.2	2,970	111.4	2,100	123.8	1,360
60	97.9	2,790	109.2	2,340	118.8	2,050	105.2	2,260	118.2	1,840		
55	110.9	1,590	121.3	1,340	129.7	1,170	118.8	1,170	131.0	940		

\*Reference radius refers to fully extended boom and appropriate jib length. A6-829-0046798  
 \*\*Capacities at loaded main boom angle.

- All capacities above the bold line are based on structural strength of jib.
- Rated load is based on loaded main boom angle with reference to horizontal, regardless of main boom length. (Ref. radius in feet is for fully extended boom 114 ft.). The LMI system will give an accurate radius indication for this condition only.
- WARNING:** Operation of this machine with heavier loads than the capacities listed is strictly prohibited. Machine tipping with every jib occurs rapidly and without advance warning.
- 46 FT. JIB WARNING:** With 46 ft. jib in working position, the boom angle must not be less than 50° since loss of stability will occur causing a tipping condition.  
**60 FT. JIB WARNING:** With 60 ft. jib in working position, the boom angle must not be less than 50° since loss of stability will occur causing a tipping condition.  
**74 FT. JIB WARNING:** With 74 ft. jib in working position, the boom angle must not be less than 55° since loss of stability will occur causing a tipping condition.  
**88 FT. JIB WARNING:** With 88 ft. jib in working position, the boom angle must not be less than 55° since loss of stability will occur causing a tipping condition.
- JIB ERECTION NOTES:**
  - Maximum length of main boom including extended fly for purpose of erecting jib below 30° main boom angle is:  
 46 ft. Jib - 95 ft.  
 60 ft. Jib - 86 ft.  
 74 ft. Jib - 77 ft.  
 88 ft. Jib - 68 ft.
  - WARNING:** Do not attempt to erect jibs over front of machine, unless boom is fully retracted (fly extended).
- Capacities listed are with fully extended outriggers only.

## NOTES FOR LIFTING CAPACITIES

- All rated loads have been tested to and meet minimum requirements of SAE J1063 OCT80 - Cantilevered Boom Crane Structures - Method of Test, and do not exceed 85% of the tipping load on outriggers (75% of the tipping load on rubber) as determined by SAE J765 OCT80 Crane Stability Test Code.
- This chart is intended as a guide only. The individual crane's load chart operating instructions and other instruction plates give details of the conditions under which the crane may be operated. ALL OF THESE INSTRUCTIONS MUST BE READ AND UNDERSTOOD PRIOR TO OPERATING THE CRANE.
- Capacities given do not include the weight of hookblocks, slings, auxiliary lifting equipment and load handling devices. Their weights MUST be added to the load to be lifted. When more than minimum required reeving is used, the additional rope weight shall be considered part of the load.
- Capacities appearing above the bold line are based on structural strength and tipping should not be relied upon as a capacity limitation.
- All capacities are for crane on firm, level surface. It may be necessary to have structural supports under the outrigger floats or tires to spread the load to a larger bearing surface.
- When either boom length or radius or both are between values listed, the smallest load shown at either the next larger radius or boom length shall be used.
- For outrigger operation, ALL outriggers shall be fully extended with tires raised free of ground before raising the boom or lifting loads.
- Tires shall be inflated to the recommended pressure before lifting on rubber.
- Unless otherwise stated, capacities are with powered boom sections equally extended.

## WEIGHT REDUCTIONS FOR LOAD HANDLING DEVICES

†46 ft. Jib Erected	12,060 lbs.
†60 ft. Jib Erected	18,015 lbs.
†74 ft. Jib Erected	25,077 lbs.
†88 ft. Jib Erected	33,236 lbs.
†33 ft. Stowed	673 lbs.
†33-58 ft. Stowed	926 lbs.

†Reduction of main boom capacities.

HOOKBLOCKS:	
15 Ton, 1 Sheave	650 lbs.
80 Ton, 6 Sheave	1,930 lbs.
Auxiliary Boom Head	230 lbs.
10 Ton Headache Ball	560 lbs.
7 1/2 Ton Headache Ball	338 lbs.

Constant improvement and engineering progress makes it necessary that we reserve the right to make specification, equipment, and price changes without notice. Illustrations shown may include optional equipment and accessories and may not include all standard equipment.

North and South America, Far East, Australasia

### GROVE MANUFACTURING COMPANY

Box 21 • Shady Grove • Pennsylvania 17256  
 (717) 597-8121 • telex: 842308 • fax: (717) 597-4062

Europe, Africa, Middle East, Indian Sub-continent

### GROVE

Telford Rd. • Bicester • Oxfordshire OX6 0TZ  
 (0869) 246800 • telex: 837447 • fax: 0869-246965