

# RTC-80100 Series II

Rough Terrain Crane  
100-ton (90.72 mt)

- 100-ton (90.72 mt) at a 10:05 radius
- 88,300 lbs (40,052 kg) overall vehicle weight
- 40' to 150' (12.2 - 45.7 m) - power, five-section formed construction boom, quick-reeve boom head
- 31' (9.5 m) - one-piece lattice fly, stowable, offsettable to 2°, 25°, and 45°
- 31' to (95.5 - 16.8 m) - piece bi-fold lattice fly, stowable, offsettable to 2°, 25°, and 45°
- Two optional 14' (4.3 m) fly extensions increasing fly length to 85'
- Maximum tip height (of 243')
- Three boom modes - A-max1, A-max2 and standard boom lifting capacities
- No deducts for stowed attachments
- Hydraulic counterweight removal
- Hydraulic pinned, removable front and rear outrigger boxes
- Removable rear winch with quick disconnects
- 21,000 lbs (9,525 kg) max line pull and 4301 fpm (137.2 m/min) max line speed
- Detroit Diesel, Series 40, 300-hp diesel engine
- Six-wheel hydrostatic drive with fully independent "A" Arm suspensions
- Travel speed 18 (29.8) km/h
- Turning radius (of 42.1')
- Ultra-Cab™ with single or dual-axis, pilot operated controls
- CabWalk™





# RTC - 801000 Series II

Unveiling the next generation of formed boom design

This new boom design not only delivers full telescoping load capability but also delivers a full chart and a maximum tip height of 243-ft. This formed boom is designed to meet greater length and stability requirements. Strategically placed wear pads are utilized on the boom to disperse the load to maximize overall stability providing greater stability at longer load radii.

Rough Terrain Crane  
100-ton (90.72 mt)

The industry's most innovative solution to big rough terrain crane maneuverability and transportability!

- Revolutionary hydrostatic drive on a three-axle, six-wheel carrier for the ultimate job site mobility
- Breakthrough transportability
- Maneuverability redefined
- 45-ton pick & carry capacity
- New U-shaped, formed boom meets greater length and stability requirements



Optional two-piece bi-fold lattice fly can be extended with two optional 15' extensions for up to 85' of fly

**Link-Belt**  
CONSTRUCTION EQUIPMENT



Three position outrigger beams extend to 22' 6" and retract to 9' 7" with hand-held outrigger controls

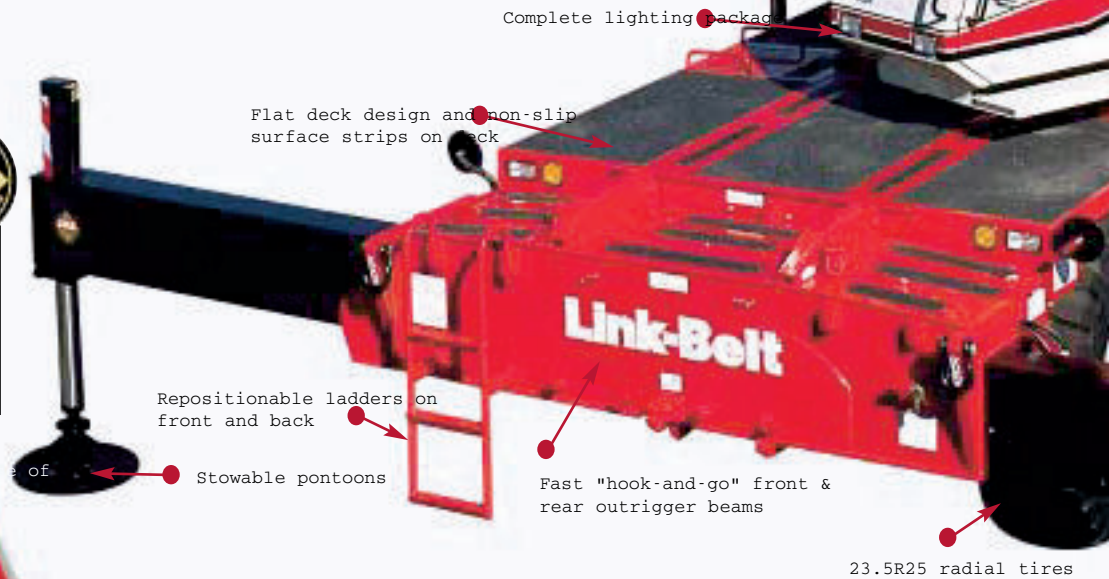

Complete lighting package

Flat deck design and non-slip surface strips on deck

Repositionable ladders on front and back

Stowable pontoons

Fast "hook-and-go" front & rear outrigger beams

23.5R25 radial tires

Independent front

Independent rear

Coordinated six wheel drive

Six wheel "crawl"

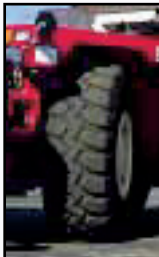





Partial counterweight and no counterweight charts

### Revolutionary hydrostatic drive on a three-axle carrier design

Not only is the RTC-80100 Series II easy to get from jobsite to jobsite with its primary creep control and jobsite maneuverability, thanks to its hydrostatic drive on each wheel. With the smaller tires giving it an overall height of 1.8m, its individual six-wheel hydrostatic drive, there is no crane in the world that comes close to the job site maneuverability and performance of the RTC-80100's outstanding pick and carry capacity coupled with its maneuverability, incredible gradeability and low height make it truly an



Catwalks on both sides of upper



Because of the innovative 6x6x6 hydrostatic drive on each wheel, the turning radius of this 45m long carrier is a remarkable







Braden winch packs with available line of 21,000 lbs

Standard load hoist system consists of main winch with two speed motor and automatic brake for pick up/down mode of operation.

Bi-directional hydraulic motor, driven through a planetary reduction unit provides precise smooth load control with minimal rpm's

Asynchronous, parallel double-over groove drums minimize rope harmonic motion, improving spooling and increasing rope service life. A two-speed primary winch is an available option.

Deflector rollers prevent premature wire rope wear when working at low boom angles.



The Ultra-Cab is roomier and quieter than traditional cabs

- Six-way adjustable fabric seat
- lift-up armrest (which deactivates control functions when raised)
- Armrest mounted, responsive single axis hydraulic controller
- Bubble light mounted on side console
- Single foot pedal
- Ducted through automotive-style directional vents
- Tilt steering column
- Sliding right side windows and swing-up roof window
- Automotive-style windshield
- Corner-mounted light gauges
- Large, sweep electric wipers
- Dashless design

cut here!

↑ Powered by 300 hp (224 kW) Detroit Series 40, six-cylinder dies 1,050 ft.-lb. (1,424 nm)

Swing-out doors provide excellent access to engine components

↓ Access is superb with strategic ladders, steps, catwalks and





# New innovative 5-section full power boom with attachment flexibility

Introducing a new boom design, Link-Belt is unveiling the next generation formed boom design for larger cranes to meet greater length and stability requirements. The U-shaped, formed construction boom design offers exceptional strength and stability throughout the crane's chart. Strategically placed wear pads are utilized throughout the boom to disperse the load and maximize the overall boom strength and stability providing greater capacities at longer loads.

- 150' (45.72 m)
- Maximum tip height (74.24' with the full attachment and main boom used in combination)
- Can telescope loads of greater capacity than power-pinned boom
- No deducts for stowed attachments



A-max<sup>1</sup>



A-max<sup>2</sup>



Standard

## A-max modes

The exclusive A-max modes offer increased capacities in close, maximum capacity picks, and provide the operator the capability to match the crane's configuration to specific job site conditions.

A-max- 95 (29 m) Inner and center sections are extended, offering maximum strength

A-max- 122' (37.34 m) Tip, outer and center sections are extended yielding maximum stability. The basic boom extension self-proportions all four sections equally.

## Optional lattice fly attachments

- 31' (9.44 m) one-piece lattice fly with lugs to allow addition of second section
- 31' - 65' (9.44 - 16.76 m)
- Also available are optional 15' fly extensions that extend the bi-fold attachment to 70' with one section and 85' using two sections
- Erection of two-piece (bi-fold) lattice fly is a one-man operation
- Exclusive design reduces side deflection when lifting load
- Easy to erect and stow
- Attachments offset to 2°, 25° and 45°

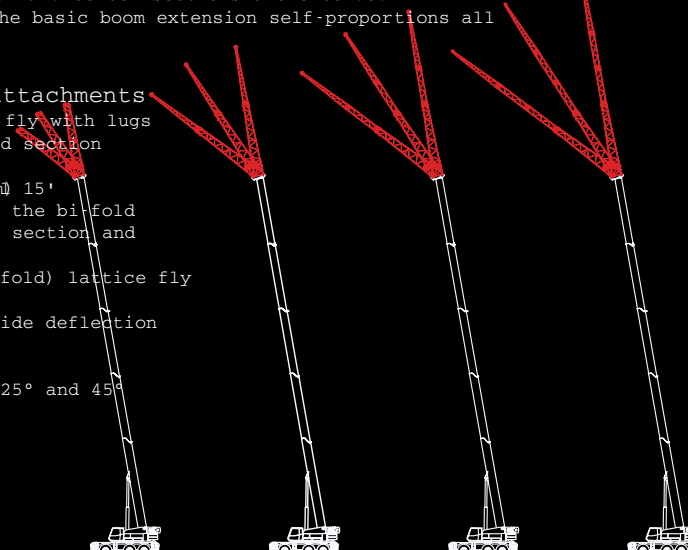

Wear shoes all the way around the circumference of the boom spreads the load out and gives you good capacity and extended wear shoe life.



Lightweight nylon head sheaves (the optional auxiliary lifting sheaves here) reduce overall machine weight and increase lift capacity.

Quick reeve boom head attachment allows rope to be easily reeved through the boom head.

Hammerhead boom nose attachment allows the operator to operate at high boom angles.

Type "RB" wire rope is standard.

cut here



## Breakthrough transportability

- Unlike any other rough terrain crane in less than an hour, without the help of a crane, the RTC-80100 is stripped to less than 90% of its original weight and is ready for transport.
- Unlike other big cranes, it does not need to be removed from the site for transport.
- Only the counterweights and outrigger to be removed from the crane's vehicle.
- Because it is under 10-ft wide and fits on a 12' 2.5" (3.72 m) overall height, the RTC-80100 Series II can travel on a weekday or weekend travel restriction like competitor's cranes without the width and weight restrictions, which require special permits.
- The crane is transported in two loads. Using an 18' conventional, drop deck trailer the unit is easily loaded out. The second trailer handles the counterweights, fly extension and outrigger box.



Link-Belt Construction Equipment Company is a leader in the design, manufacture and sales of telescopic and lattice boom cranes, with headquarters in Lexington, Kentucky.

In the recent decade, a dynamic and focused Link-Belt has emerged as a market leader in crane design and product quality standards by focusing on continuous improvement and employee empowerment.

Link-Belt operates on the principles of continuous quality improvement, ISO 9001 and established values that support the vision of quality. These principles result in reduction in waste, better use of company resources and improved employee and customer satisfaction.

With major capital improvements over the last ten years, along with continuous improvement philosophies, this facility emerged as the most modern crane facility in North America.

**Link-Belt**  
CONSTRUCTION EQUIPMENT



Lexington, Kentucky  
[www.linkbelt.com](http://www.linkbelt.com)

© Link-Belt is a registered trademark. Copyright 2003. All rights reserved. We are constantly improving our products and therefore reserve the right to change designs and specifications.

Litho in U.S.A. 3/02 #4274

# Technical Data

## Specifications & Capacities

# RTC 80100

**Series II**  
**Telescopic Boom Rough Terrain Crane**  
100 ton (90.72 metric ton)

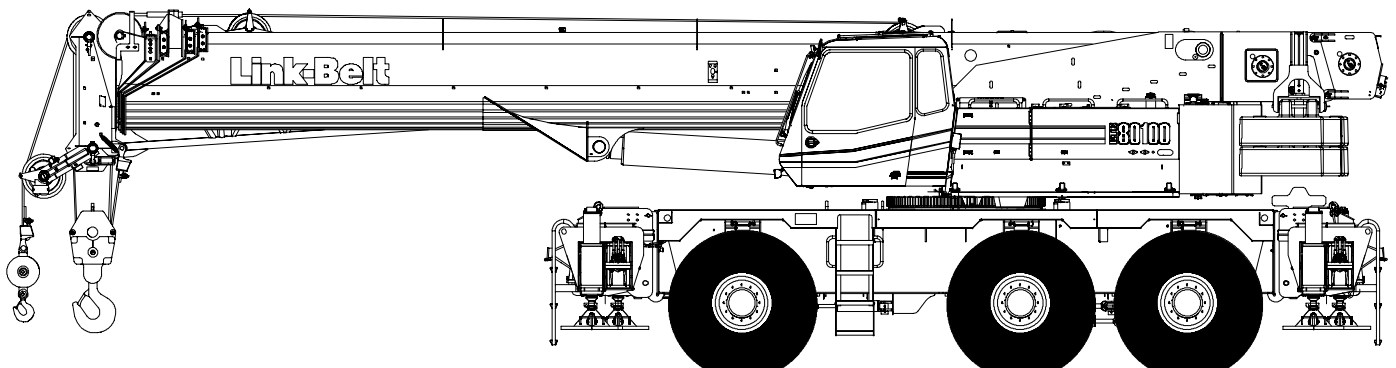

**CAUTION:** This material is supplied for reference use only. Operator must refer to in-cab Crane Rating Manual and Operator's Manual to determine allowable crane lifting capacities and assembly and operating procedures.





# Table Of Contents

<b>Boom, Attachments, and Upper Structure</b> .....	<b>1</b>
Boom .....	1
Boom Head .....	1
Boom Elevation .....	1
Auxiliary Lifting Sheave – Optional .....	1
Hook Blocks and Balls – Optional .....	1
Fly – Optional .....	1
Fly Extensions – Optional .....	1
Operator’s Cab and Controls .....	1
Swing .....	2
Electrical .....	2
Load Hoist System .....	3
Load Hoist Performance .....	3
2M Main and Optional Auxiliary Winches .....	3
Engine .....	3
Drive System .....	4
Fuel Tank .....	4
Hydraulic System .....	4
Pump Drive .....	4
Counterweight .....	4
<b>Carrier</b> .....	<b>5</b>
General .....	5
Outriggers .....	5
Steering and Wheel Drive Motors .....	5
Suspension .....	5
Tires and Wheels .....	5
Brakes .....	5
Electrical .....	5
Carrier Speeds and Gradeability .....	5
Hydraulic System .....	5
<b>Axle Loads</b> .....	<b>6</b>
<b>Transport Configuration and Weights</b> .....	<b>6</b>
<b>General Dimensions</b> .....	<b>7</b>
<b>Working Range Diagram</b> .....	<b>8</b>
<b>Boom Extend Modes</b> .....	<b>9</b>
<b>Main Boom Lift Capacity Charts – Standard</b> .....	<b>10</b>
24,000 lb Counterweight – Fully Extended Outriggers – 360° Rotation .....	10
24,000 lb Counterweight – On Tires – Stationary – Boom Centered Over Rear Between Tire Tracks .....	12
24,000 lb Counterweight – On Tires – Pick & Carry (Creep) – Boom Centered Over Rear .....	13
24,000 lb Counterweight – On Tires – Stationary – 360° Rotation .....	13

<b>Fly Attachment Lift Capacity Charts – Optional</b> .....	<b>14</b>
24,000 lb Counterweight – Fully Extended Outriggers – 360° Rotation .....	14
150 ft Main Boom Length – 2° Fly Offset .....	14
150 ft Main Boom Length – 25° Fly Offset .....	15
150 ft Main Boom Length – 45° Fly Offset .....	16
<b>Main Boom Lift Capacity Charts – Optional (Metric)</b> .....	<b>17</b>
10 885kg Counterweight – Fully Extended Outriggers – 360° Rotation .....	17
10 885kg Counterweight – On Tires – Stationary – Boom Centered Over Rear Between Tire Tracks .....	19
10 885kg Counterweight – On Tires – Pick & Carry (Creep) – Boom Centered Over Rear .....	20
10 885kg Counterweight – On Tires – Stationary – 360° Rotation .....	20
<b>Fly Attachment Lift Capacity Charts – Optional (Metric)</b> .....	<b>21</b>
10 885kg Counterweight – Fully Extended Outriggers – 360° Rotation .....	21
45.72m Main Boom Length – 2° Fly Offset .....	21
45.72m Main Boom Length – 25° Fly Offset .....	22
45.72m Main Boom Length – 45° Fly Offset .....	23



# Boom, Attachments, and Upper Structure

## ■ Boom

**Design** – Five section, formed construction of extra high tensile steel consisting of one base section and four telescoping sections. The first telescoping section extends independently by means of one, double-acting, single stage hydraulic cylinder with integral holding valves. The second telescoping section extends independently by means of one, double-acting, single stage hydraulic cylinder with integral holding valves. The third and fourth sections extend proportionally by means of one, double-acting, single stage cylinder with integrated holding valves and cables.

## Boom

- 40–150 ft (12.2–45.7m) five section full power boom
- Three boom extend modes, controlled from the operator's cab, provide superior capacities by varying the extension of the telescoping sections:
  - **Standard mode** is the full power, synchronized mode of telescoping all sections proportionally
  - **A-max<sup>1</sup>** mode (or mode 'A1') extends only the inner and center sections to 95 ft (29m) offering increased capacities for in-close, maximum capacity picks
  - **A-max<sup>2</sup>** mode (or mode 'A2') tip, outer and center sections extend to 122.5 ft (37.34m) offering maximum stability
- Mechanical boom angle indicator
- Maximum tip height for each extend mode is:
  - Standard is 159 ft 6 in (48.6m).
  - A-max<sup>2</sup> is 132 ft 6 in (40.3m)
  - A-max<sup>1</sup> is 105 ft 6 in (32.1m)

## Boom Wear Pads

- Bottom wear pads are universal for all boom sections
- Top wear pads are universal for all boom sections

## Boom Head

- Six 16.5 in (41.9cm) root diameter nylon sheaves to handle up to twelve parts of line
- Easily removable wire rope guards
- Rope dead end lugs on each side of the boom head
- Boom head is designed for quick-reeve of the hook block

## Boom Elevation

- One double acting hydraulic cylinder with integral holding valve
- Boom elevation: –3° to 80°

## Auxiliary Lifting Sheave – Optional

- Single 16.5 in (41.9m) root diameter nylon sheave
- Easily removable wire rope guards
- Does not affect erection of the fly or use of the main head sheaves

## Hook Blocks and Balls – Optional

- 100 ton (90.72mt) 6 sheave, quick-reeve hook block, with safety latch
- 80 ton (72.57mt) 5 sheave, quick-reeve hook block with safety latch
- 50 ton (45.36mt) 4 sheave, quick-reeve hook block with safety latch
- 12 ton (10.89mt) hook ball (swivel) with safety latch

## Fly – Optional

- 31 ft–55 ft (9.45–16.76m) two piece bi-fold lattice fly, stowable, offsettable to 2°, 25°, and 45°. Maximum tip height for 31 ft (9.45m) fly is 190 ft (57.9m) and for the 55 ft (16.76m) is 214 ft (65.2m).

## Fly Extensions – Optional

- One 15 ft (4.57m) lattice extension to be mounted between the 31 ft (9.45m) and 55 ft (16.76m) fly options. Maximum tip height is 228 ft 6 in (69.6m).

## ■ Operator's Cab and Controls

**Environmental Cab** – Fully enclosed, one person cab of galvaneal steel structure with acoustical insulation

Equipped with:

- Tinted and tempered glass windows
- Extra-large fixed front window with windshield wiper and washer
- Swing up roof window with windshield wiper
- Sliding left side door with large fixed window
- Sliding rear and right side windows for ventilation
- Six way adjustable, cushioned seat with seat belt and storage compartment
- Engine dependent warm-water heater with air ducts for front windshield defroster and cab floor
- Defroster fan for the front window
- Bubble level
- Circulating fan
- Adjustable sun visor
- Dome light
- Cup holder
- Fire extinguisher
- Left side viewing mirror
- Two position travel swing lock

**Air Conditioning – Optional** – Integral with cab heating system utilizing the same ventilation outlets

**Steering Column** – Pedestal type with tilt and telescope functions for operator comfort. Column includes the following controls and indicators:

- Left and right levers include:
- Horn button
  - Turn signal switch
  - Driving light switch
  - Forward/Neutral/Reverse direction switch

Panel mounted switches for:

- Travel park brake
- Steer mode selector
- 2/6 wheel drive/range selector
- Hazard flasher

Panel mounted indicator/warning lights for:

- Travel circuit temperature
- Engine oil pressure
- Travel park brake
- Service brake
- Turn signals
- Case filter restriction
- Charge filter restriction
- Pump CPU error
- Engine overspeed
- Rear wheel offset – optional
- Emergency steer – optional

**Armrest Controls** – Two dual axis hydraulic joystick controllers or optional single axis hydraulic controllers for:

- Swing
- Boom hoist
- Main rear winch
- Auxiliary front winch – optional
- Drum rotation indication
- Drum rotation indicator activation switch
- Winch high/low speed and disable switch(es)
- Third wrap selector switch – optional
- Telescopic override switches
- Warning horn button
- Swing park brake

**Outrigger Controls** – Hand held control box with umbilical cord gives the operator the freedom to view operation while setting the outriggers.

#### Foot Controls

- Boom telescope
- Swing brake
- Engine throttle
- Service brake

**Right Front Console** – Controls and indicators for:

- Engine ignition
- Engine throttle lock
- Function disable
- Fine metering
- Front windshield wiper and washer
- Cab floodlights
- Warning horn
- Heating controls
- Console dimmer switch
- Bubble level
- 12 volt power connection
- Air conditioning – optional
- Boom floodlight – optional
- Rotating beacon/Strobe light – optional
- Third wrap indicator – optional

**Cab Instrumentation** – Ergonomically positioned, analog instrumentation for crane operation including:

- Engine coolant temperature with warning indicator
- Hydraulic oil temperature with warning indicator
- Fuel level with warning indicator
- Tachometer
- Travel circuit temperature with warning indicator
- Voltmeter with warning indicator

**Rated Capacity Limiter** – Microguard graphic audio–visual warning system integrated into the dash with anti–two block and function limiter. Operating data available includes:

- Crane configuration
- Boom length and angle
- Boom head height
- Allowed load and % of allowed load
- Boom angle
- Radius of load
- Actual load
- Operator settable alarms (include):
  - Maximum and minimum boom angles
  - Maximum tip height
  - Maximum boom length
  - Swing left/right positions
  - Operator defined area (imaginary plane)
- Two 15 ft (4.57m) lattice extension to be mounted between the 31 ft (9.45m) and 55 ft (16.76m) fly options. Maximum tip height is 243 ft (74.07m).

**Internal RCL Light Bar – Optional** – Visually informs the operator when crane is approaching maximum load capacity with a series of green, yellow, and red lights.

**External RCL Light Bar – Optional** – Visually informs the ground crew when crane is approaching maximum load capacity with a series of green, yellow, and red lights.

## ■ Swing

**Motor/Planetary** – Bi–directional hydraulic swing motor mounted to a planetary reducer for 360° continuous smooth swing at 1.5 rpm.

**Swing Park Brake** – 360°, electric over hydraulic, (spring applied/hydraulic released) multi–disc brake mounted on the speed reducer. Operated by a toggle switch from the operator’s cab.

**Swing Brake** – 360°, foot operated, hydraulic applied disc brake mounted to the speed reducer.

**Swing Lock** – Two–position swing lock (boom over front or rear) operated from the operator’s cab.

**360° Positive Swing Lock – Optional** – Meets New York City requirement.

## ■ Electrical

**Swing Alarm** – Audio warning device signals when the upper is swinging.

#### Lights

- Two working lights on front of the cab
- One rotating amber beacon on top of the cab – optional
- One amber strobe beacon on top of the cab – optional
- Boom floodlight – optional



## Load Hoist System

### Load Hoist Performance

Front and Rear Winches – 7/8 in (22mm) Rope										
Layer	Maximum Line Pull		Normal Line Speed		High Line Speed		Layer		Total	
	lb	kg	ft/min	m/min	ft/min	m/min	ft	m	ft	m
1	21,022	9 535.4	141	43.0	279	85.0	125	38.1	125	38.1
2	18,986	8 611.9	156	47.5	310	94.5	138	42.0	263	80.2
3	17,820	8 083.0	172	52.4	340	103.6	152	46.3	415	126.5
4	15,868	7 197.6	187	57.0	370	112.8	165	50.3	588	179.2
5	14,669	6 653.7	202	61.6	400	121.9	179	54.6	759	231.3
6	13,639	6 186.5	217	66.1	431	131.4	192	58.5	951	289.9

Wire Rope Application		Diameter		Type	Maximum Permissible Load	
		in	mm		lb	kg
Rear Winch	Standard	7/8	22	18x19 rotation resistant – right regular lay (Type RB)	17,520	7 946.9
	Optional	7/8	22	36x7 rotation resistant – right regular lay (Type ZB)	20,920	9 489.2
Front Winch	Standard	7/8	22	18x19 rotation resistant – right regular lay (Type RB)	17,520	7 946.9
	Optional	7/8	22	36x7 rotation resistant – right regular lay (Type ZB)	20,920	9 489.2

### 2M Main and Optional Auxiliary Winches

- Axial piston, full and half displacement (2–speed) motors driven through planetary reduction unit for positive control under all load conditions.
- Grooved lagging
- Power up/down mode of operation
- Hoist drum cable follower
- Drum rotation indicator
- Drum diameter: 15 in (38.1cm)
- Rope length:
  - Front: 850 ft (215.9m)
  - Rear: 500 ft (127.0m)
- Maximum rope storage: 951 ft (289.9m)
- Terminator style socket and wedge

**Third wrap indicator – optional** – Visually and audibly warns the operator when the wire rope is on the first (bottom) layer and when the wire rope is down to the last three wraps.

### Engine

Specification	Detroit Diesel Series 40
Numbers of Cylinders	6
Cycle	4
Bore and Stroke: inch (mm)	4.59 x 5.35 (116.59 x 135.89)
Piston Displacement: in <sup>3</sup> (L)	530 (8.69)
Max. Brake Horsepower: hp (kW)	330 (246) @ 2,000 rpm
Peak Torque: ft lb (Nm)	1,050 (1 424) @ 1,300 rpm
Electric/starting systems: volts	12/12
Alternator: amps	130
Crankcase Capacity: qt (L)	28 (26.5)
<ul style="list-style-type: none"> <li>• Water/fuel separator on engine</li> <li>• 110–volt block heater</li> <li>• Ether injection – optional</li> </ul>	

## ■ Drive System

Hydrostatic type consisting of two variable speed piston pumps supplying hydraulic power to six hydraulic cam lobe wheel drive motors computer controlled for smooth and reliable operation.

## ■ Fuel Tank

One 95 gal (359.6L) capacity tank

## ■ Hydraulic System

All functions are hydraulically powered allowing positive precise control with independent or simultaneous operation of all functions.

### Main Pumps

- One, two section gear pump for the boom hoist, telescope, and charge circuits.
- Two, closed-loop piston pumps serve as travel pumps. these two pumps supply hydraulic power to the wheel motors.
- Two, closed-loop piston pumps are mounted to the rear of the two travel pumps. The left pump drives the front winch and the right pump drives the optional rear winch.
- One, pressure compensated piston pump mounted to the rear of the left winch pump supplies hydraulic power to the outrigger, counterweight removal (optional), oscillation, and travel brake circuits.
- One, single section gear pump mounted to the rear of the right side winch pump supplies hydraulic power to the swing and steering circuits.

**Hydraulic Reservoir** – 255 gal (96.5L) capacity equipped with sight level gauge. Diffuser built in for deaeration. Magnetic drain plug and large internal magnet

### Filtration

- One, 7-micron filter located inside hydraulic reservoir, accessible for easy replacement
- One, 7-micron charge filter located next to the reservoir with an in-cab indicator light
- Two, 10-micron pressure filters located next to the reservoir with change indicators
- Three, 100 mesh suction strainers located inside the hydraulic reservoir

**Counterbalance Valves** – All boom extend cylinders and boom hoist cylinder are equipped with counterbalance valves to provide load lowering and prevents accidental load drop when hydraulic power is suddenly reduced.

## ■ Pump Drive

All pumps are mounted on the pump drive gearbox and mechanically driven by the diesel engine.

## ■ Counterweight

Total of 24,000 lb (10 886kg) consisting of two removable counterweights pinned to the upper with capacities for 0 lb (0kg), 12,000 lb (5 443kg), and 24,000 lb (10 886kg) configurations.

- Optional – Hydraulic counterweight removal activated by a hand-held controller with enough cable to access the pins on each side of the counterweights.



## Carrier

### ■ General

- 9 ft 11 in (3.02m) wide
- 16 ft 1 in (4.90m) wheelbase (centerline of first axle to centerline of third axle).

**Frame** – Box–type, torsion resistant, welded construction made of high tensile steel. Equipped with front and rear towing and tie–down lugs, tow connections, and access ladders.

### ■ Outriggers

**Boxes** – Two removable, double box, front and rear pinned to carrier frame. Hydraulic outrigger pin removal – optional.

**Beams and Jacks** – Four single stage beams with Confined Area Lifting Capacities (CALC™) provide selectable outrigger extensions of full, intermediate, and retracted. Hydraulically controlled from the operator's cab with integral check valves.

**Pontoons** – Four lightweight, quick release, 26 in (0.66m) diameter, steel pontoons with contact area of 539 in<sup>2</sup> (3 477cm<sup>2</sup>) can be stored for road travel in storage racks on the carrier.

**Main Jack Reaction** – 132,000 lb (59 874kg) force and 245 psi (1 689kPa) ground bearing pressure.

### ■ Steering and Wheel Drive Motors

**Steering** – Four independent modes consisting of two wheel front, four wheel rear, six wheel, and crab. Each mode is controlled from the steering wheel and is selected by a switch in the operator's cab.

**Drive** – Three modes: 6 x 2 high, 6 x 2 low, and 6 x 6 for off highway travel

**Front Drive Motors** – Steered, driven for 6 x 2 and 6 x 6

**Rear Drive Motors** – Steered, non–driven for 6 x 2 and steered, driven for 6 x 6

### ■ Suspension

**Front** – Double “A” arms connected to oscillation cylinders that lockout when the upper structure rotates 3° past centerline

**Left Rear** – Center and rear wheels mounted on double “A” arms connected to oscillation cylinders that lockout when the upper structure rotates 3° past centerline. Oscillation occurs across left center and left rear wheels.

**Right Rear** – Center and rear wheels mounted on double “A” arms connected to oscillation cylinders that lockout when the upper structure rotates 3° past centerline. Oscillation occurs across right center and right rear wheels.

**Ride Height Adjustment** – Suspension can be lowered for transport using a hand–held controller from the ground.

### ■ Tires and Wheels

**Front and Rear** – Six (single) 23.5 x 25–2 star radials, earthmover type tires on steel disc wheels

- Spare tires and wheels – optional

### ■ Brakes

**Service** – Full hydraulic, dual circuit, disc type brakes on all wheel ends

**Parking/Emergency** – Spring loaded type, acting on front wheel ends

### ■ Electrical

Three batteries provide 12 volt operation and starting

#### Lights

- Front lighting includes two main headlights and two parking/directional indicators
- Side lighting includes two parking/directional indicators per side
- Rear lighting includes two parking/directional indicators, two parking/brake lights, and two reversing lights
- Other equipment includes hazard/warning system

### ■ Carrier Speeds and Gradeability

Variable Hydrostatic Drive	Speed		Gradeability
	Range	mph	% Grade
6 WD Low	3	4.8	55
2 WD Low	9	14.5	15
2 WD High	18.5	29.8	6

Based on a gross vehicle weight of 123,000 lb (55 792kg).

Crane operating angle must not exceed 30° (66% grade).

### ■ Hydraulic System

**Filtration** – One, 60–micron, full flow, line filter in the wheel motor case drain circuit. Filter includes an in–cab change indicator. Accessible for easy filter replacement.

## Axle Loads

Base machine with full tank of fuel and 24,000 lb (10 886kg) of counterweight	Gross Vehicle Weight <sup>(1)</sup>		Upper Facing Front				Upper Facing Rear			
			Front Axle		Rear Axle Group		Front Axles		Rear Axle Group	
	lb	kg	lb	kg	lb	kg	lb	kg	lb	kg
	126,560	57 407	39,742	18 027	86,818	39 380	61,201	27 760	65,359	29 647
Remove outrigger boxes and beams	-17,215	-7 809	-6,383	-2 895	-10,832	-4 913	-6,383	-2 895	-10,832	-4 913
Remove main counterweight	-24,182	-10 969	12,928	5 864	-37,110	-16 833	-31,518	-14,296	7,336	3 328
Cold weather start aid – ether injector	19	9.5	-2	-0.9	21	10	-2	-0.9	8	4
Pintle hook, front	20	9	29	13	-9	-4	29	13	-9	-4
Pintle hook, rear	20	9	-9	-4	29	13	-9	-4	29	13
Rear steer indicator	10	4.5	-2	-1	12	5	-2	-1	12	5
Winch roller – rear winch	110	50	-82	-37	192	87	166	75	-56	-25
Winch roller – front winch	94	42	-42	-4	141	64	119	54	-25	-11
2M auxiliary winch	1,700	771	-1,143	-518	284	1,289	2,449	1 110	-749	-348
500 ft (152m) of 7/8 in (22mm) wire rope on auxiliary winch	862	391	-579	-263	1,441	518	1,242	563	-380	-172
Air conditioning in operator's cab	184	83	74	34	110	50	67	30	117	53
360° swing lock	139	63	35	16	104	47	71	32	68	31
Fly brackets to boom base sections for fly options	370	168	497	225	-127	-58	-213	-97	583	264
31 – 55 ft (9.45 – 16.76m) offset fly (stowed)	2,632	1 194	4,223	1 916	-1,591	-722	-2,200	-998	4,832	2 192
Floodlight to boom base section	10	5	26	12	-16	-7	-18	-8	28	13
100 ton (90.72mt) hook block to front/rear bumper	1,750	794	2,537	1 151	-787	-357	-1,192	-541	2,942	1 334
80 ton (72.57mt) hook block to front/rear bumper	1,411	640	2,046	928	-635	-288	-961	-436	2,372	1 076
50 ton (45.36mt) hook block to front/rear bumper	1,200	544	1,740	789	-540	-244	-817	-370	2,017	915
12 ton (10.9mt) hook ball to front/rear bumper	722	327	1,047	475	-325	-147	-492	-223	1,214	551
Auxiliary lifting sheave	120	54	347	157	-227	-103	-254	-115	374	170

  

Tire	Maximum Load @ 20 mph (32.2km/h)
23.5R25	57,330 lb (26 004kg)

(1) Adjust gross vehicle weight and axle loading according to component weight.

Note: All weights are  $\pm 3\%$ .

## Transport Configuration and Weights

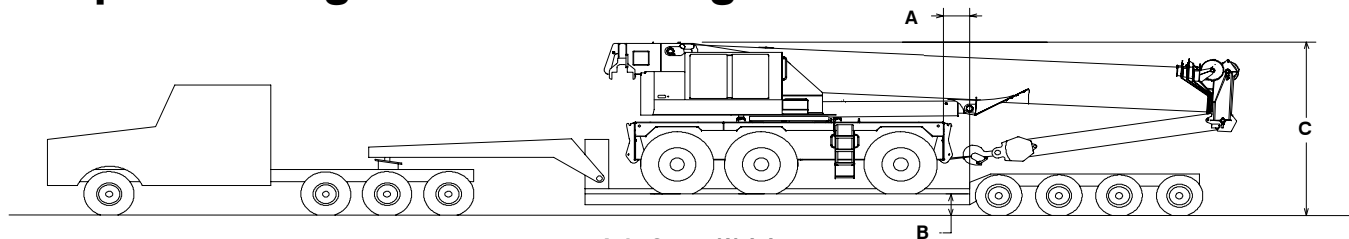

### Crane Weight: 89,984 lb (40 816kg), equipped with:

- 40–150 ft (12.19–45.72m), five section boom
- 80 ton (72.57mt) hook block
- One winch with 850 ft (259.08m) of 7/8 in (22mm) rope
- 31–55 ft (9.45–16.76m) bi-fold fly
- Winch roller
- Auxiliary arm
- Air conditioning

### Drop Off Load Weight: 44,865 lb (20 350kg)

- Two outrigger boxes with tow shackles
- 24,000 lb (10 886kg) counterweight
- Rear winch with 500 ft (152.40m) of 7/8 in (22mm) rope
- Winch roller
- 12 ton (10.9mt) hook ball

### Axle Group Weights

Empty Truck Wt.	Bed Length	Steer	Drivers	Trailer	A
48,500 lb (22 000kg)	32 ft (9.75m)	11,900 lb (5 398kg)	58,539 lb (26 553kg)	68,045 lb (30 865kg)	41 in (1.04m)

B – 18 in (0.46m) or 24 in (0.61m)

	Normal Suspension	Collapsed Suspension
C [with 18 in (0.46m) Trailer]	13 ft 8 in (4.17m)	13 ft 5 in (4.09m)
C [with 24 in (0.61m) Trailer]	14 ft 2 in (4.32m)	13 ft 11 in (4.24m)

# General Dimensions

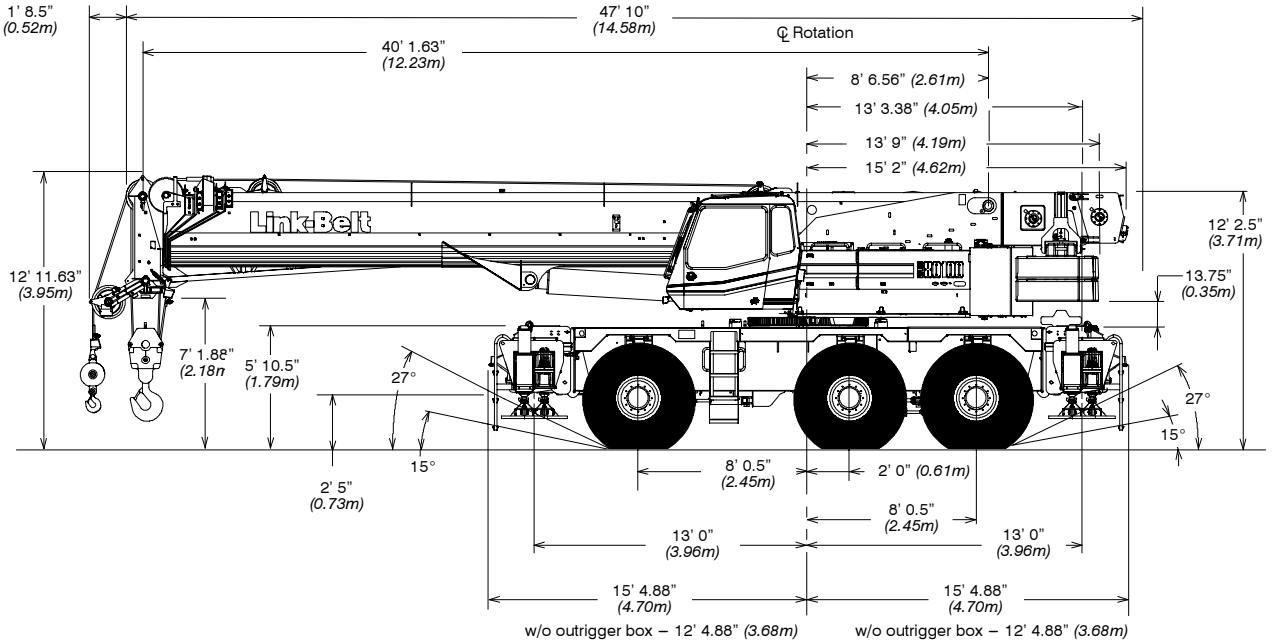

Turning Radius – 2 Wheel Steering	English	Metric
Wall to wall over carrier	44' 11"	13.69m
Wall to wall over boom attachment	55' 1"	16.79m
Curb to curb	41' 9"	12.73m
Centerline of tire	40' 5"	12.32m

Turning Radius – 6 Wheel Steering	English	Metric
Wall to wall over carrier	25' 6"	7.77m
Wall to wall over boom attachment	37' 8"	11.48m
Curb to curb	22' 3"	6.79m
Centerline of tire	20' 10"	6.35m

Tail Swing	English	Metric
of counterweight (w/o auxiliary winch)	13' 9"	3.90m
of auxiliary winch	15' 6"	4.72m

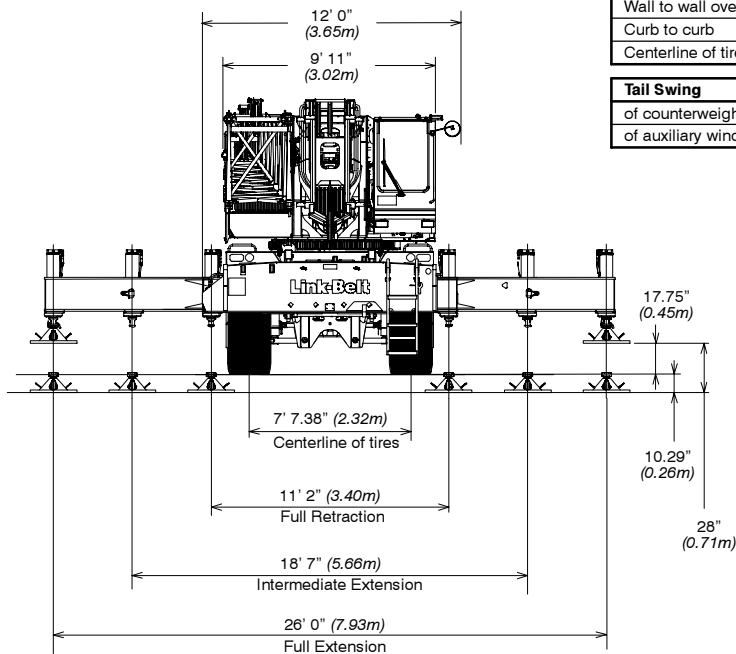



# Working Range Diagram

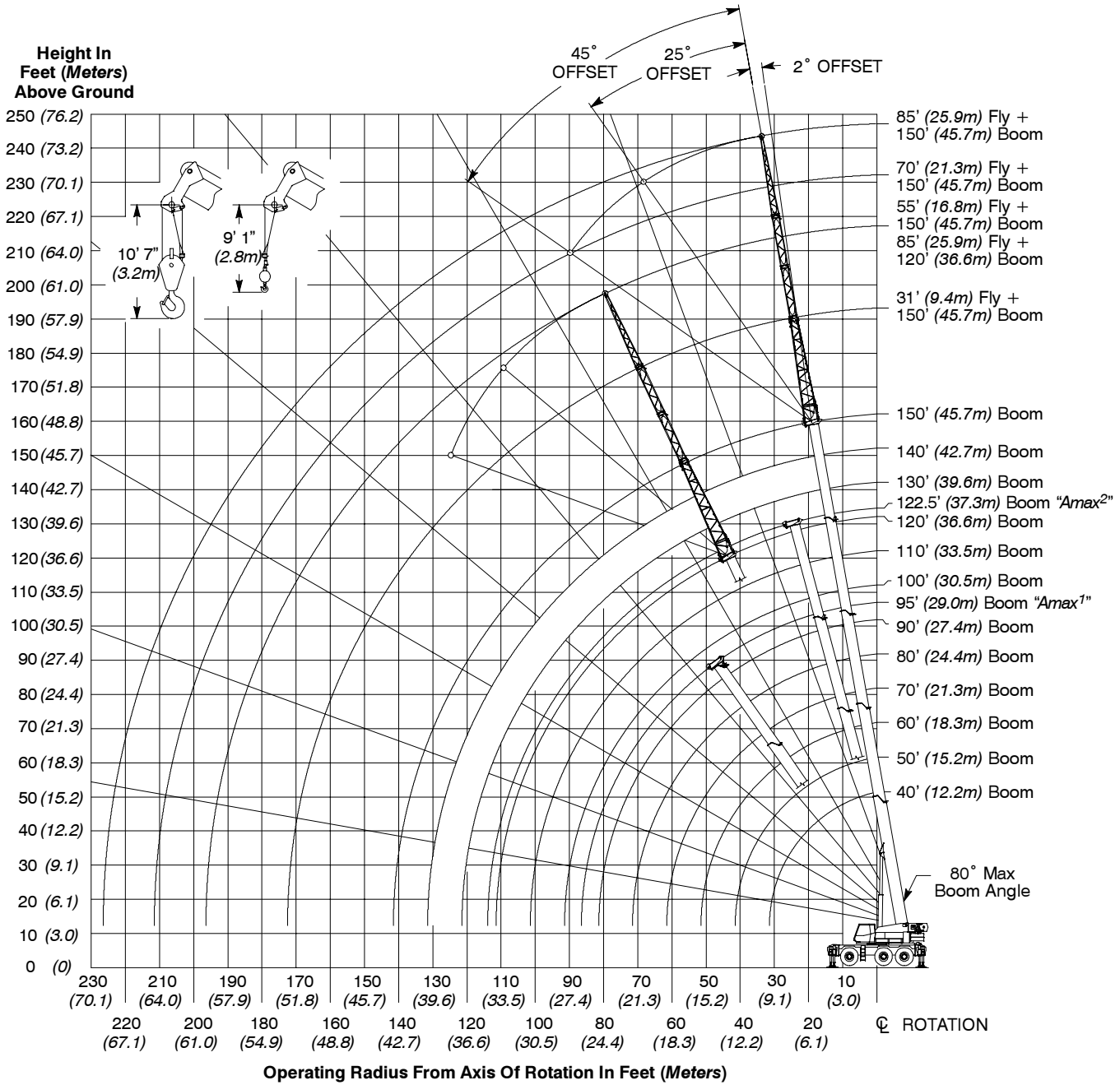

## Boom Extend Modes

### Boom Mode “Amax<sup>1</sup>”

Inner and center sections telescope simultaneously

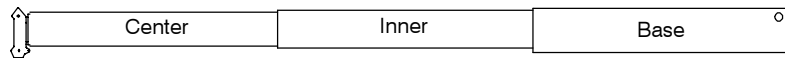

Telescope Length – ft (m)		Boom Length – ft (m)
0 (0)	0 (0)	40 (12.2)
5.0 (1.5)	5.0 (1.5)	50 (15.2)
10.0 (3.0)	10.0 (3.0)	60 (18.3)
15.0 (4.6)	15.0 (4.6)	70 (21.3)
20.0 (6.1)	20.0 (6.1)	80 (24.4)
25.0 (7.6)	25.0 (7.6)	90 (27.4)
27.5 (8.4)	27.5 (8.4)	95 (29.0)

### Boom Mode “Amax<sup>2</sup>”

Center, outer, and tip sections telescope simultaneously

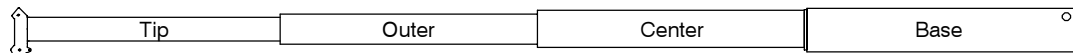

Telescope Length – ft (m)			Boom Length – ft (m)
0 (0)	0 (0)	0 (0)	40 (12.2)
3.33 (1.0)	3.33 (1.0)	3.33 (1.0)	50 (15.2)
6.66 (2.0)	6.66 (2.0)	6.66 (2.0)	60 (18.3)
10.00 (3.0)	10.00 (3.0)	10.00 (3.0)	70 (21.3)
13.33 (4.1)	13.33 (4.1)	13.33 (4.1)	80 (24.4)
16.66 (5.1)	16.66 (5.1)	16.66 (5.1)	90 (27.4)
20.00 (6.1)	20.00 (6.1)	20.00 (6.1)	100 (30.5)
23.33 (7.1)	23.33 (7.1)	23.33 (7.1)	110 (33.5)
27.50 (8.4)	27.50 (8.4)	27.50 (8.4)	122.5 (37.3)

### Boom Mode “Standard”

Inner, center, outer, and tip sections telescope simultaneously

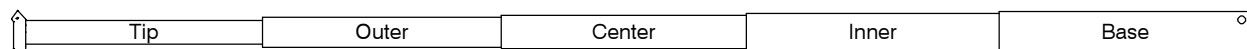

Telescope Length – ft (m)				Boom Length – ft (m)
0 (0)	0 (0)	0 (0)	0 (0)	40 (12.2)
2.5 (0.8)	2.5 (0.8)	2.5 (0.8)	2.5 (0.8)	50 (15.2)
5.0 (1.5)	5.0 (1.5)	5.0 (1.5)	5.0 (1.5)	60 (18.3)
7.5 (2.3)	7.5 (2.3)	7.5 (2.3)	7.5 (2.3)	70 (21.3)
10.0 (3.0)	10.0 (3.0)	10.0 (3.0)	10.0 (3.0)	80 (24.4)
12.5 (3.8)	12.5 (3.8)	12.5 (3.8)	12.5 (3.8)	90 (27.4)
15.0 (4.6)	15.0 (4.6)	15.0 (4.6)	15.0 (4.6)	100 (30.5)
17.5 (5.3)	17.5 (5.3)	17.5 (5.3)	17.5 (5.3)	110 (33.5)
20.0 (6.1)	20.0 (6.1)	20.0 (6.1)	20.0 (6.1)	120 (36.6)
22.5 (6.9)	22.5 (6.9)	22.5 (6.9)	22.5 (6.9)	130 (39.6)
25.0 (7.6)	25.0 (7.6)	25.0 (7.6)	25.0 (7.6)	140 (42.7)
27.5 (8.4)	27.5 (8.4)	27.5 (8.4)	27.5 (8.4)	150 (45.7)

## Main Boom Lift Capacity Charts – Standard

24,000 lb Counterweight – Fully Extended Outriggers – 360° Rotation (All Capacities Are Listed In Pounds)							
Radius (ft)	Boom Length (ft)						Radius (ft)
	40	50	60	70	80	90	
10	200,000	104,100	102,500	101,500			10
12	182,500	104,100	102,500	101,500	100,100		12
15	158,300	104,000	102,500	101,500	88,800	81,900	15
20	122,200	104,100	102,500	95,200	74,300	69,900	20
25	94,900	94,400	93,900	81,100	63,500	59,800	25
30	76,600	76,100	75,800	70,300	55,000	54,500	30
35		61,200	60,400	59,900	53,200	50,300	35
40		49,800	51,000	51,700	52,100	45,500	40
45			41,400	42,000	42,400	41,400	45
50			34,300	35,000	35,400	35,700	50
55				29,600	30,100	30,400	55
60				25,300	25,800	26,100	60
65					22,400	22,700	65
70					19,500	19,900	70
75						17,500	75
80						15,500	80

This information is not for crane operation. Operator must refer to the in-cab information for crane operation. Rated lifting capacities shown on fully extended outriggers do not exceed 85% of the tipping loads and on tires do not exceed 75% of the tipping loads.



**24,000 lb Counterweight – Fully Extended Outriggers – 360° Rotation**  
**(All Capacities Are Listed In Pounds)**

Radius (ft)	Boom Length (ft)						Radius (ft)
	95/100	110	120/122.5	130	140	150	
20	61,800**	56,000					20
25	57,400**	56,000	53,200				25
30	49,700**	53,500	46,700	46,100	32,000	30,000	30
35	43,500**	47,400	41,400	40,800	32,000	30,000	35
40	38,400**	42,400	37,000	36,400	32,000	30,000	40
45	34,800	38,100	33,300	32,800	31,500	30,000	45
50	31,800	33,900	30,100	29,600	28,500	27,500	50
55	29,300	28,500	27,300	26,900	25,900	25,000	55
60	26,400	24,700	24,400	24,400	23,600	22,700	60
65	22,900	22,800	21,000	21,000	21,000	20,800	65
70	20,100	20,300	19,200***	18,200	18,200	18,200	70
75	17,700	17,900	17,800***	16,100	16,100	16,100	75
80	15,800	16,000	16,200***	14,100	14,100	14,100	80
85	14,000	14,200	14,400***	12,300	12,400	12,400	85
90	12,500	12,700	12,900***	10,800	10,900	10,900	90
95		11,400	11,600***	9,500	9,600	9,600	95
100		10,200	10,400***	8,400	8,400	8,400	100
105			9,300***	7,300	7,400	7,400	105
110			8,400***	6,400	6,400	6,500	110
115				5,600	5,600	5,600	115
120				4,800	4,800	4,900	120
125					4,100	4,200	125
130					3,500	3,500	130
135						3,000	135
140						2,400	140

\*\* 95 ft A – max<sup>1</sup> Mode

\*\*\* 122.5 ft A – max<sup>2</sup> Mode

This information is not for crane operation. Operator must refer to the in-cab information for crane operation. Rated lifting capacities shown on fully extended outriggers do not exceed 85% of the tipping loads and on tires do not exceed 75% of the tipping loads.

24,000 lb Counterweight – On Tires – Stationary – Boom Centered Over Rear Between Tire Tracks (All Capacities Are Listed In Pounds)										
Radius (ft)	Boom Length (ft)									Radius (ft)
	40	50	60	70	80	90	100	110	122.5	
10	92,000									10
12	73,200	61,800								12
15	62,300	61,800	40,300							15
20	49,500	50,700	40,300	35,000						20
25	37,600	39,400	40,300	35,000						25
30	27,100	28,800	29,800	30,300	30,700	24,100	19,400			30
35		21,800	22,800	23,400	23,800	24,100	19,400	16,100		35
40		17,000	17,900	18,500	19,000	19,200	19,400	16,100	13,500	40
45			14,300	14,900	15,400	15,700	15,900	16,100	13,500	45
50			11,500	12,100	12,600	12,900	13,200	13,300	13,500	50
55				9,900	10,300	10,700	10,900	11,100	11,200	55
60				8,100	8,500	8,800	9,100	9,300	9,500	60
65					7,000	7,300	7,600	7,800	8,000	65
70					5,700	6,100	6,300	6,500	6,700	70
75						5,000	5,200	5,400	5,600	75
80						4,000	4,300	4,400	4,600	80
85							3,400	3,600	3,800	85
90							2,700	2,900	3,100	90
95								2,300	2,400	95
100								1,700	1,900	100

This information is not for crane operation. Operator must refer to the in-cab information for crane operation. Rated lifting capacities shown on fully extended outriggers do not exceed 85% of the tipping loads and on tires do not exceed 75% of the tipping loads.

**24,000 lb Counterweight – On Tires – Pick & Carry (Creep) – Boom Centered Over Rear**  
**(All Capacities Are Listed In Pounds)**

Radius (ft)	Boom Length (ft)									Radius (ft)
	40	50	60	70	80	90	100	110	122.5	
10	90,600									10
12	73,200	52,000								12
15	62,300	52,000	32,600							15
20	44,200	45,900	32,600	26,500						20
25	30,000	31,600	32,600	26,500						25
30	21,400	23,000	24,000	24,600	25,000	19,500	15,800			30
35		17,400	18,200	18,900	19,300	19,500	15,800	12,900		35
40		13,300	14,200	14,900	15,300	15,600	15,800	12,900	10,700	40
45			11,200	11,800	12,200	12,600	12,800	12,900	10,700	45
50			8,800	9,400	9,800	10,200	10,400	10,600	10,700	50
55				7,500	7,900	8,200	8,500	8,700	8,800	55
60				5,900	6,300	6,700	6,900	7,100	7,300	60
65					5,100	5,400	5,600	5,800	6,000	65
70					4,000	4,300	4,500	4,700	4,900	70
75						3,300	3,600	3,700	3,900	75
80						2,500	2,700	2,900	3,100	80
85							2,000	2,200	2,400	85
90								1,600	1,800	90

**24,000 lb Counterweight – On Tires – Stationary – 360° Rotation**  
**(All Capacities Are Listed In Pounds)**

Radius (ft)	Boom Length (ft)					Radius (ft)
	40	50	60	70	80	
25	19,700					25
30	13,700	15,200				30
35		11,100	12,000			35
40		8,100	9,000			40
45			6,700	7,300		45
50			4,900	5,400	5,900	50
55				4,000	4,400	55
60				2,800	3,200	60
65					2,200	65
70					1,400	70

This information is not for crane operation. Operator must refer to the in-cab information for crane operation. Rated lifting capacities shown on fully extended outriggers do not exceed 85% of the tipping loads and on tires do not exceed 75% of the tipping loads.



## Fly Attachment Lift Capacity Charts – Optional

24,000 lb Counterweight – Fully Extended Outriggers – 360° Rotation (All Capacities Are Listed In Pounds)					
150 ft Main Boom Length – 2° Fly Offset					
Radius (ft)	Fly Length (ft)				Radius (ft)
	31	55	70	85	
35	15,000				35
40	15,000				40
45	15,000	10,100	9,300		45
50	15,000	10,100	9,100	6,800	50
55	15,000	10,100	8,900	6,500	55
60	15,000	10,100	8,600	6,300	60
65	15,000	10,000	8,400	6,000	65
70	15,000	9,800	8,100	5,800	70
75	15,000	9,600	7,900	5,500	75
80	14,500	9,500	7,700	5,300	80
85	13,100	9,300	7,400	5,100	85
90	11,600	9,100	7,200	4,900	90
95	10,200	8,900	6,900	4,700	95
100	9,100	8,800	6,700	4,500	100
105	8,000	8,600	6,500	4,300	105
110	7,100	7,900	6,300	4,100	110
115	6,200	7,000	6,100	4,000	115
120	5,500	6,200	5,900	3,800	120
125	4,800	5,500	5,700	3,700	125
130	4,100	4,900	5,100	3,500	130
135	3,600	4,300	4,500	3,400	135
140	3,000	3,700	3,900	3,300	140
145	2,500	3,200	3,400	3,200	145
150	2,100	2,800	2,900	3,000	150
155	1,700	2,300	2,500	2,600	155
160	1,300	1,900	2,100	2,200	160
165		1,600	1,700	1,800	165

This information is not for crane operation. Operator must refer to the in-cab information for crane operation. Rated lifting capacities shown on fully extended outriggers do not exceed 85% of the tipping loads and on tires do not exceed 75% of the tipping loads.

<b>24,000 lb Counterweight – Fully Extended Outriggers – 360° Rotation</b>					
<b>(All Capacities Are Listed In Pounds)</b>					
<b>150 ft Main Boom Length – 25° Fly Offset</b>					
<b>Radius (ft)</b>	<b>Fly Length (ft)</b>				<b>Radius (ft)</b>
	<b>31</b>	<b>55</b>	<b>70</b>	<b>85</b>	
50	14,700				50
55	14,500				55
60	14,200				60
65	14,000	8,200			65
70	13,800	8,100			70
75	13,600	7,900			75
80	13,400	7,800	5,500		80
85	13,200	7,700	5,400		85
90	12,800	7,600	5,200	3,300	90
95	11,300	7,400	5,100	3,200	95
100	10,100	7,200	5,000	3,100	100
105	8,900	7,100	4,900	3,000	105
110	7,900	6,900	4,700	2,900	110
115	7,000	6,800	4,600	2,800	115
120	6,200	6,700	4,600	2,700	120
125	5,400	6,500	4,500	2,700	125
130	4,700	6,000	4,400	2,600	130
135	4,100	5,300	4,300	2,500	135
140	3,500	4,700	4,200	2,500	140
145	2,900	4,100	4,200	2,400	145
150	2,400	3,500	4,000	2,400	150
155	1,900	3,000	3,500	2,300	155
160	1,500	2,600	3,000	2,300	160
165		2,100	2,500	2,200	165
170		1,700	2,100	2,200	170
175		1,300	1,700	1,900	175
180			1,300	1,600	180
185				1,300	185

This information is not for crane operation. Operator must refer to the in-cab information for crane operation. Rated lifting capacities shown on fully extended outriggers do not exceed 85% of the tipping loads and on tires do not exceed 75% of the tipping loads.

<b>24,000 lb Counterweight – Fully Extended Outriggers – 360° Rotation</b>					
<b>(All Capacities Are Listed In Pounds)</b>					
<b>150 ft Main Boom Length – 45° Fly Offset</b>					
<b>Radius (ft)</b>	<b>Fly Length (ft)</b>				<b>Radius (ft)</b>
	<b>31</b>	<b>55</b>	<b>70</b>	<b>85</b>	
60	12,700				60
65	12,500				65
70	12,400				70
75	12,300				75
80	12,200	6,600			80
85	12,100	6,500			85
90	12,000	6,400			90
95	11,900	6,300	4,200		95
100	10,700	6,200	4,200		100
105	9,500	6,100	4,100		105
110	8,400	6,100	4,000	2,300	110
115	7,400	6,000	4,000	2,300	115
120	6,500	5,900	4,000	2,200	120
125	5,700	5,900	3,900	2,200	125
130	4,900	5,900	3,900	2,200	130
135	4,300	5,900	3,900	2,100	135
140		5,200	3,800	2,100	140
145		4,500	3,800	2,100	145
150		3,900	3,800	2,100	150
155		3,300	3,800	2,100	155
160		2,800	3,500	2,100	160
165		2,300	2,900	2,100	165
170			2,400	2,100	170
175			1,900	2,100	175
180			1,500	1,900	180
185				1,500	185
190				1,200	190

This information is not for crane operation. Operator must refer to the in-cab information for crane operation. Rated lifting capacities shown on fully extended outriggers do not exceed 85% of the tipping loads and on tires do not exceed 75% of the tipping loads.

## Main Boom Lift Capacity Charts – Optional (Metric)

10 885kg Counterweight – Fully Extended Outriggers – 360° Rotation (All Capacities Are Listed In Kilograms)							
Radius (m)	Boom Length (m)						Radius (m)
	12.19	15.2	18.3	21.3	24.4	27.4	
3	90 700	47 200	46 450	46 000			3
3.5	85 000	47 200	46 450	46 000			3.5
4	78 350	47 200	46 450	46 000	43 250		4
4.5	72 550	47 200	46 450	46 000	40 550	37 100	4.5
5	67 550	47 200	46 450	46 000	38 150	35 950	5
6	56 400	47 200	46 450	43 550	33 950	32 050	6
7	47 450	47 200	46 450	39 100	30 550	28 850	7
8	40 650	40 450	40 250	35 350	27 650	26 100	8
9	34 650	34 250	33 900	32 250	25 250	24 700	9
10		27 750	27 450	27 200	24 100	23 950	10
12		20 550	21 000	21 250	21 450	20 850	12
14			15 950	16 200	16 350	16 500	14
16				12 850	13 050	13 150	16
18				10 400	10 600	10 750	18
20					8 800	8 900	20
22						7 550	22
24						6 400	24

This information is not for crane operation. Operator must refer to the in-cab information for crane operation. Rated lifting capacities shown on fully extended outriggers or on tires do not exceed 75% of the tipping loads.

**10 885kg Counterweight – Fully Extended Outriggers – 360° Rotation**  
**(All Capacities Are Listed In Kilograms)**

Radius (m)	Boom Length (m)						Radius (m)
	28.96/30.5	33.5	36.6/37.34	39.6	42.7	45.72	
6	28 000**	25 050					6
7	27 650**	23 450					7
8	25 050**	21 550	24 100				8
9	22 850**	19 950	21 450	21 150	14 500	13 600	9
10	20 900**	18 500	19 750	19 450	14 500	13 600	10
12	17 700**	16 100	17 000	16 750	14 500	13 600	12
14	15 500	14 200	14 800	14 600	14 000	13 500	14
16	13 250	12 650	12 400	12 450	12 300	11 850	16
18	10 800	10 900	10 000	10 050	10 050	10 050	18
20	9 000	9 050	9 150***	8 250	8 250	8 250	20
22	7 650	7 700	7 800***	6 900	6 950	6 950	22
24	6 500	6 600	6 650***	5 800	5 800	5 800	24
26	5 550	5 650	5 700***	4 900	4 900	4 900	26
28		4 850	4 950***	4 100	4 150	4 150	28
30		4 200	4 300***	3 500	3 500	3 500	30
32			3 700***	2 950	2 950	2 950	32
34			3 250***	2 450	2 450	2 450	34
36				2 000	2 050	2 050	36
38					1 650	1 700	38
40					1 350	1 350	40
42						1 050	42

\*\* 28.96m A–max<sup>1</sup> Mode

\*\*\* 37.34m A–max<sup>2</sup> Mode

This information is not for crane operation. Operator must refer to the in-cab information for crane operation. Rated lifting capacities shown on fully extended outriggers or on tires do not exceed 75% of the tipping loads.



**10 885kg Counterweight – On Tires – Stationary – Boom Centered Over Rear Between Tire Tracks  
(All Capacities Are Listed In Kilograms)**

Radius (m)	Boom Length (m)									Radius (m)
	12.19	15.2	18.3	21.3	24.4	27.4	30.5	33.5	37.34	
3	41 700									3
3.5	34 200	28 050								3.5
4	31 200	28 050								4
4.5	28 600	28 050	18 200							4.5
5	26 350	26 150	18 200							5
6	22 600	23 250	18 200	15 850						6
7	17 200	17 900	18 200	15 850						7
8	13 550	14 250	14 600	14 850						8
9	10 950	11 600	12 000	12 200	12 350	10 500	7 800			9
10		9 650	10 000	10 250	10 400	10 500	7 800	6 100		10
12		6 850	7 250	7 500	7 700	7 800	7 800	6 100	6 150	12
14			5 400	5 650	5 800	5 950	6 000	6 100	6 150	14
16				4 300	4 450	4 600	4 700	4 750	4 800	16
18				3 300	3 450	3 600	3 700	3 750	3 800	18
20					2 700	2 800	2 900	2 950	3 050	20
22						2 150	2 250	2 350	2 400	22
24						1 650	1 750	1 800	1 900	24
26							1 350	1 400	1 450	26
28								1 050	1 100	28
30								750	800	30

This information is not for crane operation. Operator must refer to the in-cab information for crane operation. Rated lifting capacities shown on fully extended outriggers or on tires do not exceed 75% of the tipping loads.

**10 885kg Counterweight – On Tires – Pick & Carry (Creep) – Boom Centered Over Rear**  
 (All Capacities Are Listed In Kilograms)

Radius (m)	Boom Length (m)									Radius (m)
	12.19	15.2	18.3	21.3	24.4	27.4	30.5	33.5	37.34	
3	41 550									3
3.5	34 200	28 050								3.5
4	31 200	28 050								4
4.5	28 600	28 050	14 700							4.5
5	24 450	24 100	14 700							5
6	17 850	18 500	14 700	15 850						6
7	13 650	14 350	14 700	14 900						7
8	10 800	11 400	11 800	12 000						8
9	8 700	9 300	9 650	9 900	10 050	8 550	6 400			9
10		7 700	8 050	8 300	8 450	8 550	6 400	4 900		10
12		5 400	5 750	6 000	6 200	6 300	6 400	4 900	4 950	12
14			4 200	4 450	4 600	4 750	4 800	4 900	4 950	14
16				3 300	3 450	3 600	3 700	3 750	3 800	16
18				2 400	2 600	2 700	2 800	2 900	2 950	18
20					1 900	2 050	2 150	2 200	2 300	20
22						1 500	1 600	1 650	1 750	22
24						1 050	1 150	1 200	1 300	24
26							750	850	900	26
28								600		28

**10 885kg Counterweight – On Tires – Stationary – 360° Rotation**  
 (All Capacities Are Listed In Kilograms)

Radius (m)	Boom Length (m)					Radius (m)
	12.19	15.2	18.3	21.3	24.4	
7	9 050					7
8	7 050					8
9	5 600	6 150				9
10		5 000				10
12		3 300	3 650			12
14			2 450	2 700		14
16				1 850	2 000	16
18				1 150	1 350	18
20					800	20

This information is not for crane operation. Operator must refer to the in-cab information for crane operation. Rated lifting capacities shown on fully extended outriggers or on tires do not exceed 75% of the tipping loads.

## Fly Attachment Lift Capacity Charts – Optional (Metric)

10 885kg Counterweight – Fully Extended Outriggers – 360° Rotation (All Capacities Are Listed In Kilograms)					
45.72m Main Boom Length – 2° Fly Offset					
Radius (m)	Fly Length (m)				Radius (m)
	9.45	16.76	21.34	25.91	
12	6 800				12
14	6 800	4 550	4 200		14
16	6 800	4 550	4 050	3 000	16
18	6 800	4 550	3 950	2 850	18
20	6 800	4 550	3 800	2 700	20
22	6 800	4 400	3 650	2 550	22
24	6 100	4 300	3 500	2 450	24
26	5 200	4 200	3 350	2 300	26
28	4 400	4 100	3 200	2 150	28
30	3 750	4 000	3 050	2 050	30
32	3 200	3 500	2 950	1 950	32
34	2 700	3 050	2 800	1 850	34
36	2 300	2 600	2 650	1 750	36
38	1 900	2 200	2 300	1 650	38
40	1 600	1 900	1 950	1 600	40
42	1 300	1 550	1 650	1 500	42
44	1 000	1 300	1 350	1 400	44
46	800	1 050	1 100	1 150	46
48	550	850	900	900	48
50		650	700	700	50
52				550	52
54				350	54
56				200	56
58				50	58

This information is not for crane operation. Operator must refer to the in-cab information for crane operation. Rated lifting capacities shown on fully extended outriggers or on tires do not exceed 75% of the tipping loads.

<b>10 885kg Counterweight – Fully Extended Outriggers – 360° Rotation</b>					
<b>(All Capacities Are Listed In Kilograms)</b>					
<b>45.72m Main Boom Length – 25° Fly Offset</b>					
<b>Radius (m)</b>	<b>Fly Length (m)</b>				<b>Radius (m)</b>
	<b>9.45</b>	<b>16.76</b>	<b>21.34</b>	<b>25.91</b>	
16	6 600				16
18	6 450				18
20	6 350	3 700			20
22	6 200	3 650			22
24	6 100	3 550	2 500		24
26	5 700	3 500	2 450		26
28	4 850	3 400	2 350	1 450	28
30	4 150	3 300	2 250	1 400	30
32	3 550	3 200	2 200	1 350	32
34	3 050	3 100	2 150	1 300	34
36	2 550	3 050	2 100	1 250	36
38	2 150	2 700	2 000	1 200	38
40	1 800	2 300	1 950	1 150	40
42	1 500	1 950	1 950	1 150	42
44	1 200	1 650	1 850	1 100	44
46	900	1 350	1 550	1 050	46
48	650	1 100	1 250	1 050	48
50		850	1 050	1 000	50
52		650	800	950	52
54		450	600	700	54
56				500	56
58				350	58
60				150	60

This information is not for crane operation. Operator must refer to the in-cab information for crane operation. Rated lifting capacities shown on fully extended outriggers or on tires do not exceed 75% of the tipping loads.

<b>10 885kg Counterweight – Fully Extended Outriggers – 360° Rotation</b>					
<b>(All Capacities Are Listed In Kilograms)</b>					
<b>45.72m Main Boom Length – 45° Fly Offset</b>					
<b>Radius (m)</b>	<b>Fly Length (m)</b>				<b>Radius (m)</b>
	<b>9.45</b>	<b>16.76</b>	<b>21.34</b>	<b>25.91</b>	
18	5 750				18
20	5 700				20
22	5 600				22
24	5 550	3 000			24
26	5 500	2 950			26
28	5 150	2 850			28
30	4 400	2 800	1 900		30
32	3 750	2 750	1 850		32
34	3 200	2 750	1 850	1 050	34
36	2 700	2 700	1 800	1 000	36
38	2 300	2 700	1 800	1 000	38
40	1 900	2 550	1 750	1 000	40
42	1 550	2 150	1 750	950	42
44		1 850	1 750	950	44
46		1 500	1 750	950	46
48		1 200	1 500	950	48
50		950	1 200	950	50
52			950	950	52
54			700	900	54
56				650	56
58				450	58
60				200	60

This information is not for crane operation. Operator must refer to the in-cab information for crane operation. Rated lifting capacities shown on fully extended outriggers or on tires do not exceed 75% of the tipping loads.



**Link-Belt Construction Equipment Company**      Lexington, Kentucky      [www.linkbelt.com](http://www.linkbelt.com)

©Link-Belt is a registered trademark. Copyright 2006. We are constantly improving our products and therefore reserve the right to change designs and specifications.