

GMK6250-L

**product
guide**

features

- 250-ton (220 mt) capacity
- 51-236 ft. (15.5-72 m) 6-section full power MEGAFORM™ boom with Twin-Lock™ pinning
- 43-72 ft. (13-22 m) hydraulic offset bi-fold swingaway
- 2 X 26 ft. (8 m) intermediate lattice inserts
- 154,300 lb. (77.15 t) counterweight with hydraulic removal system
- Chassis engine: Mercedes-Benz OM 502 LA, 571 hp (420 kW), torque 1991 ft./lb. (2700 Nm)
- Superstructure engine: Mercedes-Benz OM 904 LA, 177 hp (130 kW), torque 487 ft./lb. (660 Nm)
- MEGATRAK™ independent hydro-pneumatic suspension

contents

Features	2
Specifications	3
Dimensions	5
Counterweight Dimensions	6
Working Range Main Boom	7
Load Charts	8
Working Range Hydraulic Offset Swingaway	10
Hydraulic Offset Swingaway Charts	11
Boom Extension Configurations	13



All Terrain Crane

features

2



MEGATRAK™ independent suspension and all wheel steer system allows all wheels to remain on the ground at all times so stresses and weight are not continually transferred between axles



ECOS (Electronic Crane Operating System) computerized system continuously monitors and controls principle crane functions as programmed by an operator



EKS4 electronic load moment indicator operates in conjunction with ECOS continuously displaying crane configuration and load moment data

MEGAFORM™ incorporates a “U” shape boom design which forms a natural cradle position for boom sections which eliminates stiffeners thus reducing weight and increasing capacity

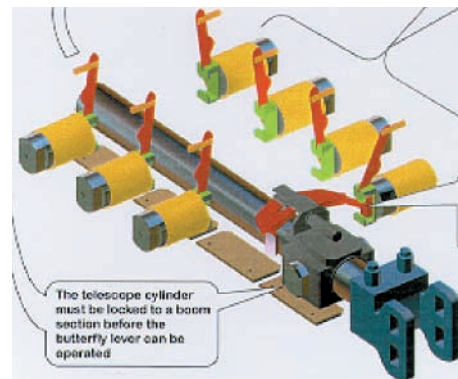
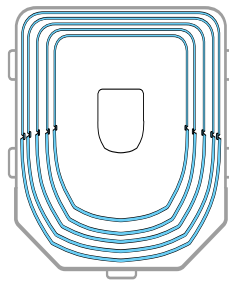

TWIN-LOCK™ boom pinning mechanism automatically pins the sections in position using two horizontal large diameter boom pins

specifications

3

Superstructure



Boom

51 ft. - 236 ft. (15.5 m - 72 m) six section, full-power boom with patented Twin-Lock™ boom pinning system. Maximum tip height: 246 ft. (75 m)



Boom Elevation

Single lift cylinder with safety valve provides boom angle from -1.5° to +82°.



Lattice Extension

43 ft. - 72 ft. (13 m - 22 m) lattice swingaway extension. Hydraulically offsettable 5° - 40° with hydraulic luffing.



*Optional Lattice Jib Extension

Two 26 ft. (8 m) inserts for use with lattice swingaway extension to increase length up to 98 ft. (30 m) or 125 ft. (38 m).



Load Moment & Anti-Two Block System

Load moment and anti-two block system with audio/visual warning and control lever lockout provides electronic display of boom angle, length, radius, tip height, relative load moment, maximum permissible load, load indication and warning of impending two-block condition.



Cab

All aluminum construction cab is tiltable (approximately 20°) and includes safety glass and adjustable operator's seat with hydraulic suspension. Other features include engine dependent hot water heater, armrest integrated crane controls, and ergonomically arranged instrumentation.



Swing

Three swing gears with axial piston fixed displacement motors provide swing speed of 0 - 1.7 RPM thru planetary gear box. Also provided is a spring applied, hydraulically released automatic swing brake with foot-operated release for free swing.



Counterweight

154,300 lbs. (70 000 kg) consisting of various sections with hydraulic installation/removal system (See counterweight configuration on page 12).



Engine

Mercedes Benz OM904LA, diesel, 4 cylinders, water-cooled, turbocharged, 177 HP (130 kW) at 2200 rpm. Max. torque: 487 ft. lbs. (660 Nm) at 1200 rpm.

Engine emission: EUROMOT/EPA/CARB (off highway)



Fuel Tank Capacity

53 gal. (200 L)



Hydraulic System

Three separate circuits, 2 axial piston variable displacement pumps, with electronic power limiting control and 1 axial piston variable displacement pump for swing. Standard thermostatically controlled oil cooler keeps oil at optimum operating temperature.

Tank capacity: 259 gal. (980 L)



Control System

Full electronic control of all crane movements is accomplished using electrical control levers with automatic reset to zero. Controls are integrated with the LMI and engine management system by CAN-BUS.



Hoist

Main and auxiliary hoist are powered by axial piston variable displacement motor with planetary gear and brake. "Thumb-thumper" hoist drum rotation indicator alerts operator of hoist movement.

	Main	Auxiliary
Line length:	984 ft. (300 m)	755 ft. (230 m)
Rope diameter:	22 mm	22 mm
Line speed:	426 ft./min.	426 ft./min.
Line pull:	21,000 lbs. (93.4 kN)	21,000 lbs. (93.4 kN)



Electrical System

24 V system with three-phase alternator 28 V/80 A, 2 batteries 12 V/170 Ah.

*Optional Equipment

- *Engine-independent hot water heater, with engine pre-heater
- *Second spotlight
- *Stereo/cassette player
- *Air conditioning
- *Stainless steel exhaust system

* Denotes optional equipment

GMK6250-L

GROVE

specifications

Carrier

4



Chassis

Box-type, torsion resistant frame is fabricated from high-strength steel.



Outrigger System

Hydraulic two-stage outrigger beams are extended by a single hydraulic cylinder and two cables. Outriggers can adjust to two positions:

Fully extended (100%) - 27 ft. 11 in. (8.5 m)

Partially extended (50%) - 19 ft. 8 in. (6 m)

Four 29.5 in. x 32 in. (750 mm x 810 mm), self stowing, steel outrigger pads provide rigid lifting base. Outrigger controls are located on both sides of the carrier. An electronic level indicator is located next to each outrigger control box.



Engine

Mercedes-Benz OM502LA, diesel, 8 cylinders, water-cooled, turbocharged, 571 HP (420 kW) at 1800 rpm. Max. torque: 1991 ft. lbs. (2700 Nm) at 1080 rpm

Engine emission: EUROMOT/EPA/CARB (on highway)



Fuel Tank Capacity

132 gal. (500 L)



Transmission

Allison automatic CLT 755, 5 forward and 1 reverse speed. Transfer case with 2 speeds and inter-axle differential lock.



Drive/Steer

12 x 6 x 12

*12 x 8 x 12



Axles

6 axles. 1, 2, 4 and 5 are drive/steer. Axles 3 and 6 are steer only.



Suspension

GMK6250-L features the Grove exclusive MEGATRAK™ suspension. This revolutionary design features an independent hydro-pneumatic system with hydraulic lockout acting on all wheels. The suspension can be raised 6-1/2 in. (170 mm) or lowered 5 in. (130 mm) both longitudinally and transversely and features an automatic leveling system for on-highway travel.



Tires

12 tires, 16.00 R25 (vehicle width 9' 10")



Steering

Dual circuit steering system is hydraulic power assisted with a transfer case mounted, ground driven, emergency steering pump. Axles 1, 2, 3, 5 and 6 steer on highway. Separate steering of the 4th, 5th and 6th axle for all wheel steer and crab-steer is controlled by an electric rocker switch.



Brakes

A dual circuit air system operates on all wheels with a spring-applied, air released parking brake acting on axles 2, 4, 5 and 6. An air dryer is fitted to remove moisture from the air system. Auxiliary exhaust brake and constant throttle brake is standard.



Cab

Two-man, aluminum construction driver's cab includes the following features: safety glass; driver and passenger seats with hydraulic suspension, engine-dependent hot water heater, complete instrumentation and driving controls.



Electrical System

24 V system with three-phase alternator 28 V/100 A, 2 batteries 12 V/170 Ah.



Maximum Speed

48 mph (77km/h) with 20.5 R25 tires



Gradeability (Theoretical)

46% with 20.5 R25 tires

Miscellaneous Standard Equipment

Boom removal kit; trailing boom kit (less dolly); additional hydraulic oil cooler; spare tire and wheel - 20.5 R25 with carry bracket; flashing amber warning light on carrier cab; working light; tool kit; fire extinguisher; rooster sheave; radio cassette in carrier cab.

* Optional Equipment

- * Electric driveline retarder
- * 20.5 R25 tires (vehicle width 10 ft. 2 in. [3.1 m])
- * 14.00 R25 tires (vehicle width 9 ft. 9 in. [2.98 m])
- * Outrigger pressure measurement devices
- * Engine-independent hot water heater, with engine pre-heater
- * Trailing boom "boost" weight transfer kit
- * Air conditioning

GMK6250-L

GROVE

dimensions

5

Weights & Dimensions

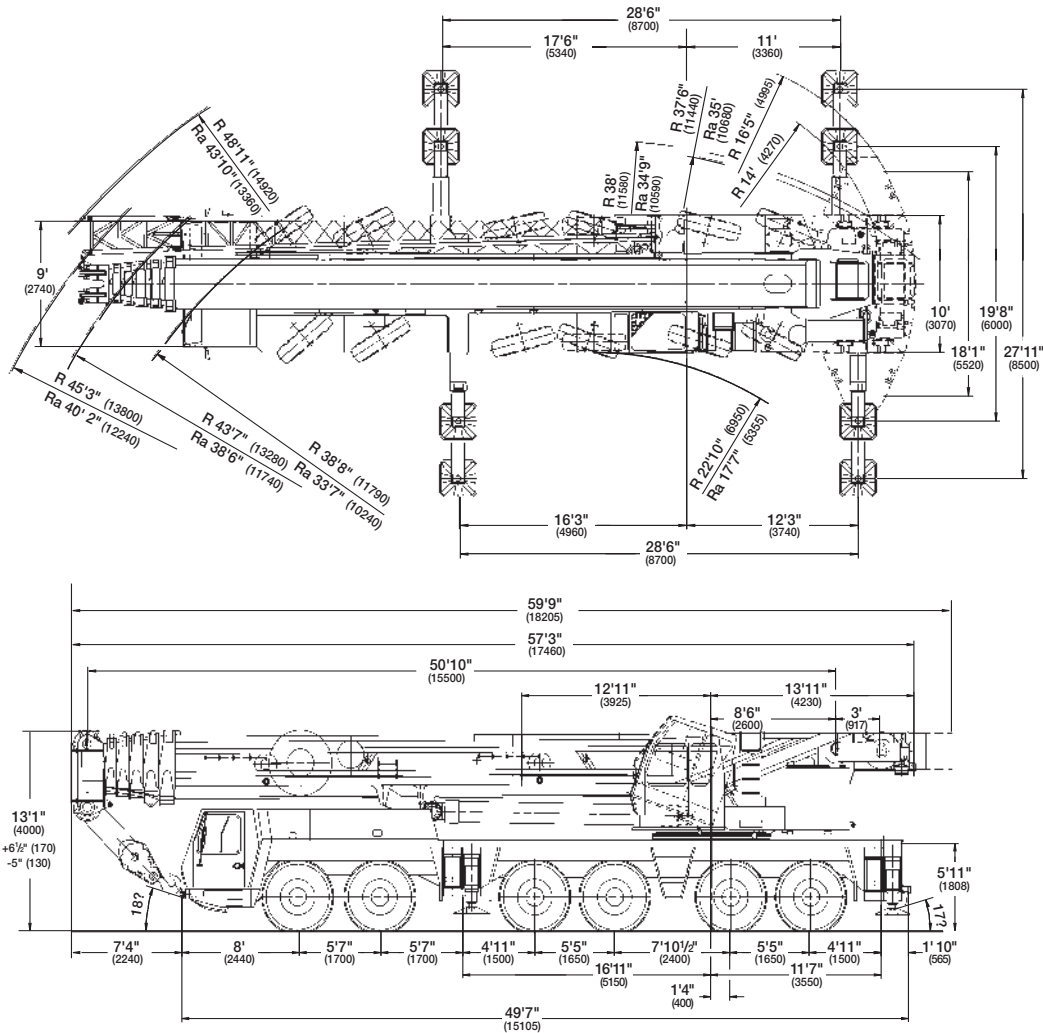

Note: () Reference dimensions in mm

BASIC WEIGHTS (LBS.)	Axles 1 & 2	Axles 3 - 6	Total
With Mercedes Power, 20.5 R25 Tires (12x6x12)	47,140	98,294	145,434
Additions:			
Outrigger Pads	0	772	772
Auxiliary Hoist	-(2,892)	6,618	3,726
Additional Hydraulic Oil Cooler (Standard)	-(55)	143	88
Brackets & Hydraulic Reeling Drum for Lattice Extension	485	22	507
Lattice Extension - 43/72 ft	6,997	-(1,530)	5,467
Spare Tire - 14.00 R25	-(425)	1,010	584
Spare Tire - 16.00 R25	-(522)	1,239	717
Spare Tire - 20.5 R25	-(593)	1,402	809
Boom Removal Equipment (Standard)	53	212	265
12x8x12 drive	966	-(106)	860
Removal:			
Front Outrigger Beams & Jacks	-(3,377)	-(1,980)	-(5,357)
Rear Outrigger Beams & Jacks	3,732	-(9,652)	-(5,919)
Boom Assembly (minus lift cylinder)*	-(29,972)	-(20,889)	-(50,861)
Lift Cylinder*	-(1,457)	-(3,018)	-(4,475)
16.00 R25 Tires in lieu	-(370)	-(741)	-(1,111)
14.00 R25 Tires in lieu	-(899)	-(1,799)	-(2,698)
Rear Outrigger Box	6,753	-(17,555)	-(10,802)

*Reflects weights with superstructure facing forward

GMK6250-L

GROVE

counterweight

6

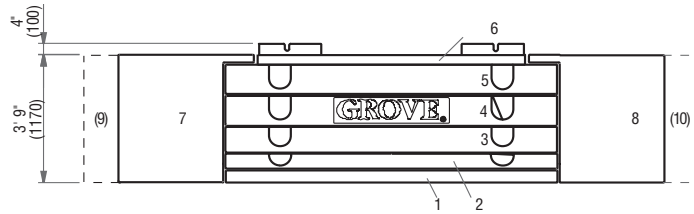

- 1. 11,980 lbs. (5 400 kg)
- 2. 11,200 lbs. (5 100 kg)
- 3. 18,700 lbs. (8 500 kg)
- 4. 24,300 lbs. (11 000 kg)
- 5. 23,100 lbs. (10 500 kg)
- 6. 7,700 lbs. (3 500 kg)
- 7. 22,000 lbs. (10 000 kg)
- 8. 22,000 lbs. (10 000 kg)
- 9. 6,600 lbs. (3 000 kg)
- 10. 6,600 lbs. (3 000 kg)

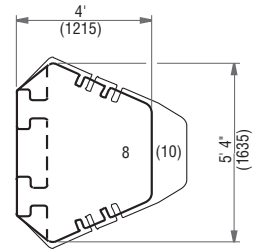
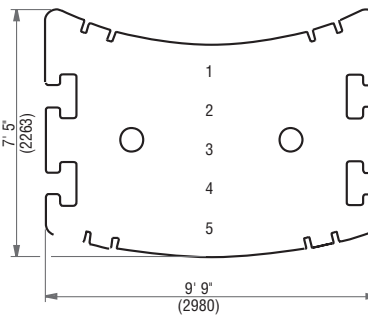
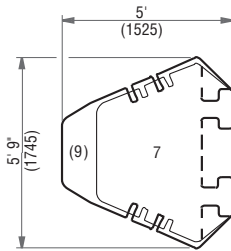
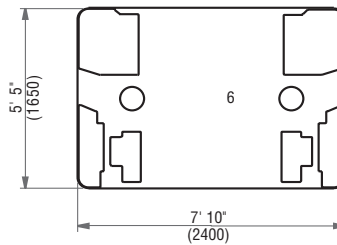
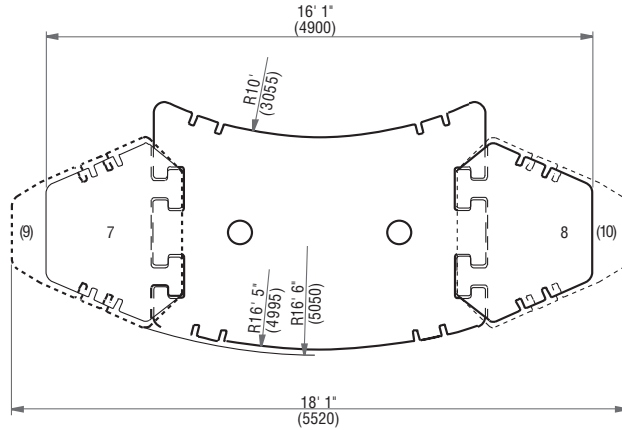

Note: () Reference dimensions in mm

	1	2	3	4	5	6	7	8	9	10
	X	X								
23,100 lbs.	X	X								
30,800 lbs.	X	X				X				
49,600 lbs.	X	X	X			X				
73,800 lbs.	X	X	X	X		X				
97,000 lbs.	X	X	X	X	X	X				
141,000 lbs.	X	X	X	X	X	X	*	*		
154,300 lbs.	X	X	X	X	X	X	X	X	X	X

*NOTE: To utilize 141,000 lb. (64 000 kg) load chart optional counterweights for 7 & 8 may be provided weighing 22,050 lbs. (10 000 kg) each.

GMK6250-L

GROVE

working range

51'-236' (15.5-72m) Main Boom

7

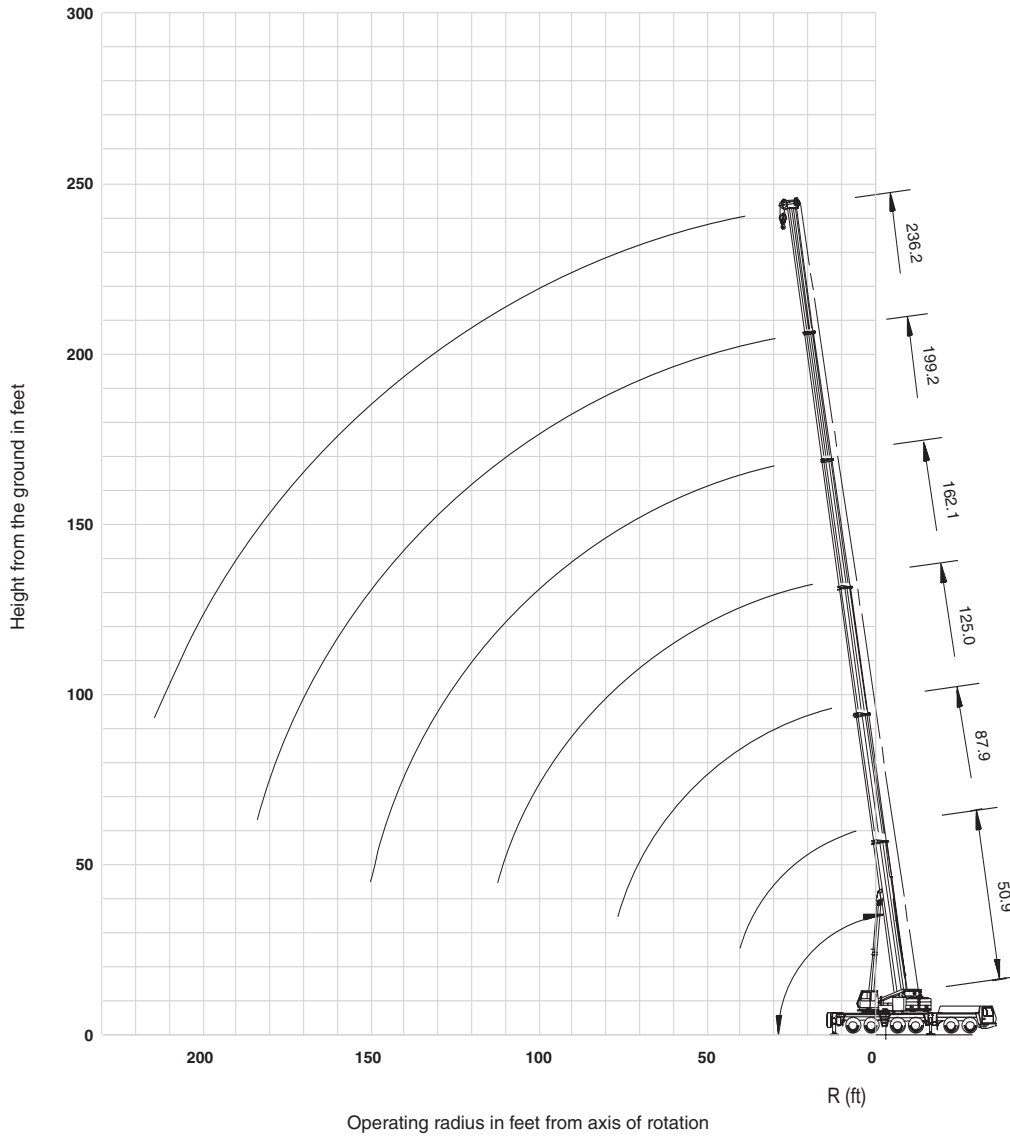





THIS CHART IS ONLY A GUIDE AND SHOULD NOT BE USED TO OPERATE THE CRANE. The individual crane's load chart, operating instructions and other instructional plates must be read and understood prior to operating the crane.

GMK6250-L





GROVE

load charts

8

		   										
		Pounds (thousands)										
Feet		50.9	69.4	87.9	106.5	125.0	143.5	162.1	180.6	199.2	217.7	236.2
8	*406.0											
10	382.0	308.0										
15	288.0	272.0	208.0									
20	238.0	228.0	208.0	157.0	120.0							
25	200.0	196.0	188.0	157.0	120.0	93.0						
30	169.0	171.0	163.0	150.0	120.0	93.0	69.0	52.0				
35	140.0	147.0	143.0	139.0	118.0	93.0	69.0	52.0				
40		124.0	121.0	123.0	111.0	89.0	69.0	53.0	39.6	30.8		
45		107.0	104.0	106.0	103.0	84.0	65.0	52.0	39.6	30.8		
50		94.0	90.0	92.0	94.0	79.0	61.0	52.0	39.6	30.8	26.4	
55		81.0	79.0	81.0	83.0	75.0	58.0	50.0	39.6	30.8	26.4	
60			70.0	75.0	74.0	71.0	54.0	47.0	39.6	30.8	26.4	
65			62.0	68.0	67.0	67.0	50.0	43.8	39.2	30.8	26.4	
70			56.0	62.0	60.0	62.0	47.0	41.4	37.2	30.8	26.4	
75				56.0	55.0	57.0	44.0	39.0	35.4	30.8	26.4	
80				51.0	52.0	52.0	41.2	36.6	33.4	30.8	26.4	
85				47.0	48.0	47.0	38.2	34.2	31.6	29.4	26.4	
90				43.2	45.0	43.6	36.0	32.4	29.8	28.0	26.0	
95					42.0	40.2	34.0	30.4	28.2	26.6	25.2	
100					39.0	37.2	32.6	28.4	26.6	25.4	24.2	
105					36.4	34.6	31.4	26.4	25.0	24.0	22.8	
110					31.8	32.0	30.2	24.6	23.6	22.6	21.4	
115						29.8	29.0	22.6	22.0	21.2	20.0	
120						27.8	28.0	21.0	20.6	19.8	18.8	
125						26.0	27.0	20.0	19.0	18.4	18.0	
130							23.4	25.8	19.2	17.6	17.0	
135								24.2	18.6	16.6	16.2	
140								22.4	18.0	15.8	15.4	
145								20.2	17.4	15.0	14.6	
150								13.8	17.0	14.4	14.0	
155									16.4	13.8	13.4	
160									15.8	13.2	12.6	
165										12.6	12.0	
170										12.2	11.6	
175										11.8	11.2	
180										11.4	10.6	
185											10.2	
190											9.8	
195											9.2	
200											8.8	
205												8.0
210												7.6
215												7.0
												6.2

Loads >350,000 lb. can only be lifted with additional equipment
*Over rear, 19.7 ft. outrigger span

		   										
		Pounds (thousands)										
Feet		50.9	69.4	87.9	106.5	125.0	143.5	162.1	180.6	199.2	217.7	236.2
8	*406.0											
10	382.0	308.0										
15	288.0	272.0	208.0									
20	238.0	228.0	208.0	157.0	120.0							
25	188.0	190.0	186.0	157.0	120.0	93.0						
30	149.0	151.0	147.0	149.0	120.0	93.0	69.0	52.0				
35	122.0	124.0	121.0	123.0	118.0	93.0	69.0	52.0				
40		106.0	101.0	104.0	101.0	89.0	69.0	52.0	39.6	30.8		
45		92.0	86.0	92.0	86.0	84.0	65.0	52.0	39.6	30.8		
50		80.0	75.0	80.0	75.0	75.0	61.0	52.0	39.6	30.8	26.4	
55		70.0	65.0	70.0	70.0	66.0	58.0	50.0	39.6	30.8	26.4	
60			56.0	62.0	63.0	58.0	54.0	47.0	39.6	30.8	26.4	
65			49.0	55.5	56.0	52.0	48.0	43.8	39.2	30.8	26.4	
70			45.0	50.0	51.0	47.0	43.6	41.4	37.2	30.8	26.4	
75				47.0	46.0	42.0	41.4	37.2	35.4	30.8	26.4	
80				42.4	41.4	38.0	39.2	33.4	33.4	30.8	26.4	
85				38.4	37.2	34.4	35.8	30.0	30.2	29.4	26.4	
90				34.8	33.6	32.4	32.6	28.2	27.2	27.6	26.0	
95					30.2	31.0	29.8	27.0	24.6	25.0	25.2	
100					27.4	29.6	27.4	25.6	23.2	23.8	23.6	
105					25.4	27.0	24.8	24.4	22.2	22.6	21.6	
110					24.4	24.6	22.6	23.0	21.0	21.4	19.6	
115						22.6	20.4	21.4	20.0	20.2	18.0	
120						20.8	18.8	19.4	18.8	18.6	16.4	
125						19.0	18.0	17.8	17.8	17.0	15.0	
130							17.4	17.4	16.2	16.8	15.8	
135								16.8	14.8	15.2	14.4	
140								15.4	14.0	14.0	13.2	
145								14.4	13.4	13.2	12.0	
150								13.2	12.8	12.2	11.0	
155									12.0	11.0	9.8	
160									11.0	10.0	9.0	
165										9.2	8.0	
170										8.4	7.2	
175										7.6	6.4	
180										6.8	5.6	
185											4.8	
190											4.2	
195											3.6	
200												3.0

Loads >350,000 lb. can only be lifted with additional equipment
*Over rear, 19.7 ft. outrigger span

GMK6250-L

GROVE

THIS CHART IS ONLY A GUIDE AND SHOULD NOT BE USED TO OPERATE THE CRANE. The individual crane's load chart, operating instructions and other instructional plates must be read and understood prior to operating the crane.

load charts

51 - 236 ft. (15.5 - 72 m) 49,600 lbs. (22.5mt) 100% Spread 360°

Pounds (thousands)

Feet	50.9	69.4	87.9	106.5	125.0	143.5	162.1	180.6	199.2	217.7	236.2
10	382.0	308.0									
15	288.0	272.0	208.0								
20	213.0	212.0	205.0								
25	161.0	163.0	148.0	140.0	120.0						
30	127.0	130.0	112.0	114.0	105.0	93.0					
35	102.0	104.0	89.0	93.0	91.0	84.0	69.0	52.0			
40		85.0	73.0	80.0	76.0	69.0	64.0	52.0	39.6	30.8	
45		69.0	66.0	69.0	64.0	58.0	57.0	51.0	39.6	30.8	
50		59.0	61.0	59.0	55.0	52.0	50.0	43.2	39.6	30.8	26.4
55		50.0	53.0	51.0	47.0	48.0	43.6	40.6	36.6	30.8	26.4
60			45.0	44.0	41.2	42.2	38.2	37.8	34.2	30.8	26.4
65			39.2	39.2	38.0	37.4	34.2	33.4	32.6	29.4	26.4
70			34.0	34.6	36.0	33.2	32.4	30.0	30.0	27.6	24.8
75				30.2	32.2	29.6	29.6	28.4	26.6	24.4	21.6
80				28.0	29.0	26.4	26.4	25.4	23.8	21.6	19.0
85				25.8	25.8	24.8	23.8	22.8	21.2	19.2	16.6
90				23.0	23.0	23.2	21.4	20.4	19.0	17.0	14.6
95					20.4	21.2	19.2	18.4	17.0	15.0	12.6
100					18.2	19.0	18.0	16.6	15.2	13.2	11.0
105					16.2	17.0	16.2	14.8	13.6	11.6	9.4
110					14.4	15.2	14.6	13.4	12.0	10.2	8.2
115						13.6	13.0	12.0	10.8	9.0	6.8
120						12.2	11.6	10.8	9.6	7.8	5.6
125						11.0	10.2	9.6	8.4	6.6	4.6
130						9.8	9.2	8.4	7.4	5.6	3.6
135							8.0	7.4	6.4	4.8	2.8
140							7.2	6.4	5.6	3.8	
145							6.2	5.4	4.6	3.0	
150							5.4	4.6	3.8		
155								4.0	3.0		
160								3.2			

Loads >350,000 lb. can only be lifted with additional equipment

51 - 236 ft. (15.5 - 72 m) 30,800 lbs. (14mt) 100% Spread 360°

Pounds (thousands)

Feet	50.9	69.4	87.9	106.5	125.0	143.5	162.1	180.6	199.2	217.7	236.2
10	382.0	308.0									
15	288.0	272.0	208.0								
20	199.0	202.0	175.0	157.0	120.0						
25	150.0	147.0	125.0	125.0	114.0	93.0					
30	112.0	111.0	93.0	98.0	94.0	85.0	69.0	52.0			
35	84.0	86.0	81.0	82.0	75.0	68.0	63.0	52.0			
40		70.0	70.0	67.0	62.0	60.0	56.0	48.0	39.6	30.8	
45		59.0	58.0	56.0	52.0	52.0	47.0	44.0	38.4	30.8	
50		48.0	49.0	47.0	48.0	44.0	41.6	39.0	34.2	30.8	26.4
55		39.8	41.8	40.2	41.4	38.0	37.4	35.8	33.4	29.4	26.4
60			35.8	35.8	35.8	33.6	32.4	31.0	29.0	26.2	23.2
65			30.2	32.8	31.2	30.8	29.0	27.0	25.2	22.6	19.8
70			26.2	28.8	27.4	27.2	25.4	23.6	21.8	19.6	17.0
75				25.0	24.0	24.0	22.4	20.8	19.2	16.8	14.4
80				21.8	21.2	21.2	19.8	18.2	16.6	14.6	12.2
85				19.0	18.8	19.0	17.4	16.0	14.6	12.6	10.2
90				16.4	16.4	16.8	15.4	14.0	12.6	10.8	8.4
95					14.2	15.0	13.6	12.4	11.0	9.2	6.8
100					12.4	13.2	12.0	10.8	9.4	7.6	5.4
105					10.8	11.6	10.6	9.4	8.2	6.4	4.2
110					9.4	10.2	9.4	8.2	6.8	5.2	3.0
115						8.8	8.2	7.0	5.8	4.0	
120						7.6	7.0	6.0	4.8	3.0	
125						6.6	5.8	5.0	3.8		
130						5.6	5.0	4.2	3.0		
135							4.0	3.4			
140							3.2				

Loads >350,000 lb. can only be lifted with additional equipment

51 - 236 ft. (15.5 - 72 m) 0 lbs. (0mt) 100% Spread 360°

Pounds (thousands)

Feet	50.9	69.4	87.9	106.5	125.0	143.5	162.1	180.6	199.2	217.7	236.2
10	382.0	308.0									
15	260.0	212.0	172.0								
20	152.0	137.0	116.0	112.0	97.0						
25	100.0	95.0	89.0	81.0	72.0	68.0					
30	68.0	69.0	65.0	62.0	58.0	54.0	48.0	41.4			
35	49.0	51.0	50.0	50.0	45.0	43.2	39.2	35.4			
40		38.6	39.4	39.4	36.4	34.8	31.8	28.6	25.8	22.2	
45		30.0	31.4	32.0	29.6	28.6	26.0	23.4	21.0	17.8	
50		23.8	25.4	26.4	24.4	23.8	21.6	19.2	17.0	14.2	11.2
55		19.0	20.6	21.8	20.2	19.8	17.8	15.8	13.8	11.4	8.6
60			16.8	18.2	16.8	16.6	14.8	13.0	11.2	8.8	6.2
65			13.8	15.2	14.0	13.8	12.2	10.6	9.0	6.8	4.2
70			11.2	12.8	11.6	11.6	10.0	8.6	7.0	5.0	
75				10.6	9.6	9.6	8.2	6.8	5.4	3.4	
80				8.8	7.8	8.0	6.6	5.2	3.8		
85				7.2	6.2	6.4	5.2	3.8			
90				5.8	5.0	5.2	4.0	2.6			
95					3.8	4.0	2.8				
100					2.8	3.0					

Loads >350,000 lb. can only be lifted with additional equipment

THIS CHART IS ONLY A GUIDE AND SHOULD NOT BE USED TO OPERATE THE CRANE. The individual crane's load chart, operating instructions and other instructional plates must be read and understood prior to operating the crane.

working range

236' (72m) Main Boom With 43'-72' (13-22m) Lattice Swingaway Extension and Two 26' (8m) Inserts

10

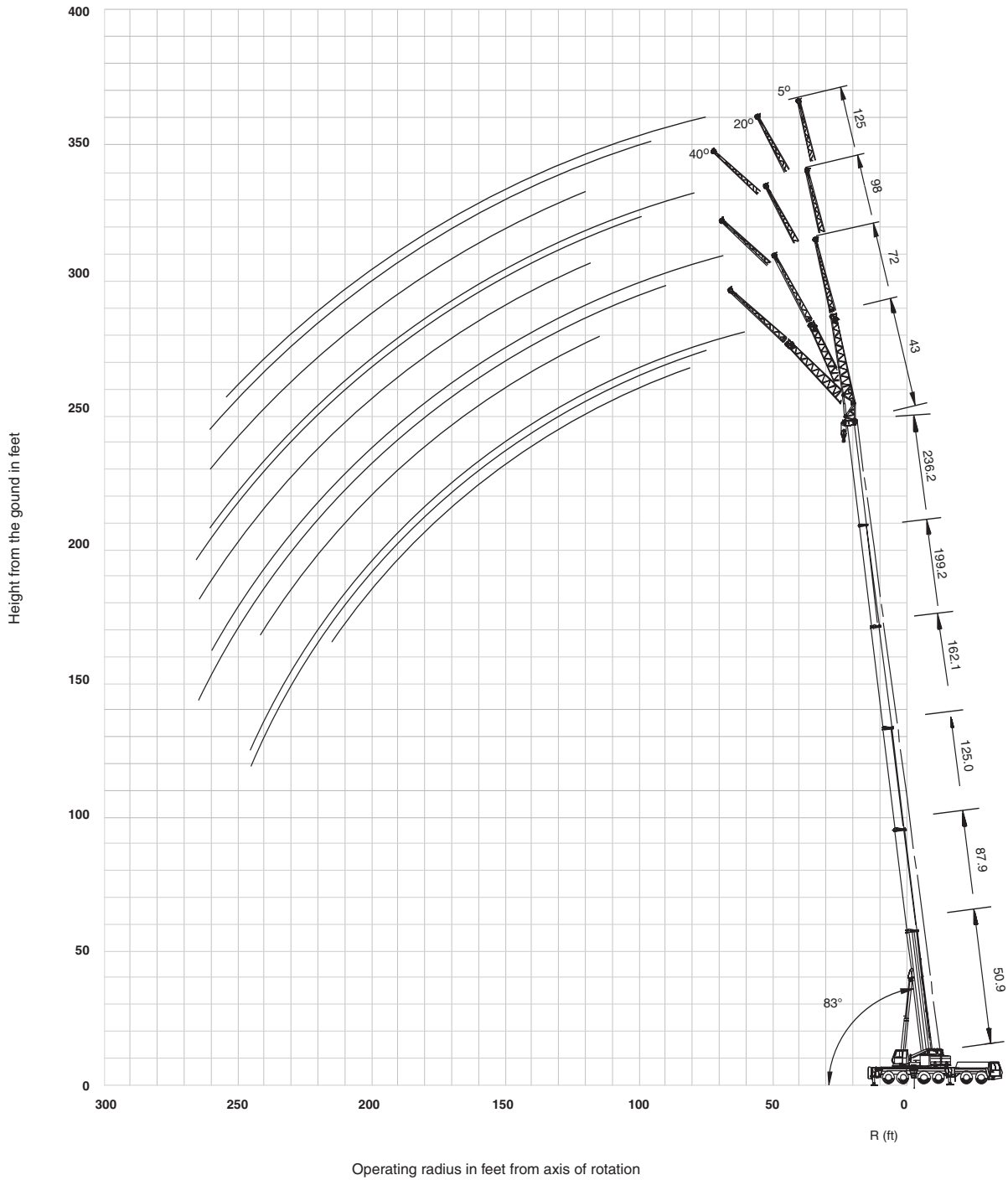

GMK6250-L

GROVE

THIS CHART IS ONLY A GUIDE AND SHOULD NOT BE USED TO OPERATE THE CRANE. The individual crane's load chart, operating instructions and other instructional plates must be read and understood prior to operating the crane.

load charts

236 ft. (72 m)
 43-72-98-125 ft. (13-22-30-38 m)
 154,300 lbs. (70mt)
 100% 27'11" Spread
 360°

Pounds (thousands)

Feet	43 FT			72 FT			98 FT			125 FT		
	5°	20°	40°	5°	20°	40°	5°	20°	40°	5°	20°	40°
50	13.8											
55	13.8											
60	13.8	13.6		9.0								
65	13.8	13.6		9.0								
70	13.8	13.6		9.0								
75	13.8	13.6	13.6	9.0			6.6					
80	13.8	13.6	13.6	9.0	8.6		6.6			4.4		
85	13.8	13.6	13.6	9.0	8.6		6.6			4.4		
90	13.8	13.6	13.6	9.0	8.6		6.6	6.6		4.4		
95	13.8	13.6	13.6	9.0	8.6		6.6	6.6		4.4	4.4	
100	13.8	13.6	13.6	9.0	8.6	8.6	6.6	6.6		4.4	4.4	
105	13.8	13.6	13.6	9.0	8.6	8.6	6.6	6.6		4.4	4.4	
110	13.8	13.6	13.6	9.0	8.6	8.6	6.6	6.6		4.4	4.4	
115	13.8	13.6	13.6	9.0	8.6	8.6	6.6	6.6	6.6	4.4	4.4	
120	13.8	13.6	13.6	9.0	8.6	8.6	6.6	6.6	6.6	4.4	4.4	4.2
125	13.8	13.6	13.6	9.0	8.6	8.6	6.6	6.6	6.6	4.4	4.4	4.2
130	13.4	13.4	13.6	9.0	8.6	8.6	6.6	6.6	6.6	4.4	4.4	4.2
135	13.0	13.0	13.2	9.0	8.6	8.6	6.6	6.6	6.6	4.4	4.4	4.2
140	12.6	12.6	12.8	9.0	8.6	8.6	6.6	6.6	6.6	4.4	4.4	4.2
145	12.2	12.2	12.4	9.0	8.6	8.6	6.6	6.6	6.6	4.4	4.4	4.2
150	11.8	11.8	12.0	9.0	8.6	8.6	6.6	6.6	6.6	4.4	4.4	4.2
155	11.4	11.2	11.6	9.0	8.6	8.6	6.6	6.6	6.6	4.4	4.4	4.2
160	10.8	10.8	11.2	9.0	8.6	8.6	6.6	6.6	6.6	4.4	4.4	4.2
165	10.2	10.4	10.8	9.0	8.6	8.6	6.6	6.6	6.4	4.4	4.4	4.2
170	9.8	9.8	10.2	8.8	8.6	8.6	6.6	6.6	6.4	4.4	4.2	4.2
175	9.2	9.4	9.8	8.4	8.6	8.6	6.6	6.4	6.4	4.4	4.2	4.2
180	8.6	8.8	9.4	8.2	8.4	8.4	6.4	6.2	6.2	4.2	4.2	4.2
185	8.2	8.4	9.0	7.8	8.0	8.2	6.2	6.2	6.0	4.2	4.2	4.2
190	7.6	8.0	8.4	7.4	7.8	8.0	6.0	6.0	6.0	4.2	4.0	4.2
195	7.2	7.6	8.0	7.2	7.4	7.8	5.8	5.8	5.8	4.2	4.0	4.0
200	6.8	7.0	7.4	6.8	7.2	7.6	5.6	5.8	5.8	4.0	4.0	4.0
205	6.4	6.6		6.4	6.8	7.4	6.4	5.6	5.6	4.0	4.0	4.0
210	6.0	6.2		6.0	6.6	7.2	5.0	5.2	5.4	4.0	3.8	4.0
215	5.6	5.8		5.8	6.2	6.8	4.8	5.0	5.2	3.8	3.8	4.0
220	5.2	5.4		5.4	6.0	6.4	4.6	4.8	5.2	3.8	3.8	3.8
225	4.6	4.8		5.0	5.6	6.0	4.4	4.6	5.0	3.4	3.6	3.8
230	4.0	4.2		4.8	5.2		4.0	4.4	4.8	3.2	3.4	3.6
235	3.4	3.6		4.4	4.8		3.8	4.2	4.6	3.0	3.2	3.4
240	2.8	3.0		4.0	4.4		3.6	4.0	4.2	2.8	3.2	3.4
245		2.6		3.6	4.0		3.2	3.6	4.0	2.6	3.0	3.2
250				3.2	3.6		3.0	3.4		2.4	2.8	3.0
255				2.8	3.2		2.6	3.0		2.2	2.6	3.0
260				2.2	2.6			2.6		2.4	2.6	2.6

11

236 ft. (72 m)
 43-72-98-125 ft. (13-22-30-38 m)
 154,300 lbs. (70mt)
 100% 27'11" Spread
 360°

Pounds (thousands)

Feet	43 FT		72 FT		98 FT		125 FT		
	5°-20°	20°-40°	5°-20°	20°-40°	5°-20°	20°-40°	5°-20°	20°-40°	
55									
60	13.2								
65	13.2								
70	13.2								
75	13.2	13.6							
80	13.2	13.6		8.6					
85	13.2	13.6		8.6					
90	13.2	13.6		8.6		6.6			
95	13.2	13.6		8.6		6.6	4.4		
100	13.2	13.6		8.6	8.2	6.6	4.4		
105	13.2	13.6		8.6	8.2	6.6	4.4		
110	13.2	13.6		8.6	8.2	6.6	4.4		
115	13.2	13.6		8.6	8.2	6.6	4.4		
120	13.2	13.6		8.6	8.2	6.6	6.6	4.4	4.2
125	13.2	13.4		8.6	8.2	6.6	6.6	4.4	4.2
130	12.8	13.0		8.6	8.2	6.6	6.6	4.4	4.2
135	12.4	12.6		8.6	8.2	6.6	6.6	4.4	4.2
140	12.0	12.2		8.6	8.2	6.6	6.6	4.4	4.2
145	11.6	11.8		8.6	8.2	6.6	6.6	4.4	4.2
150	11.2	11.4		8.6	8.2	6.6	6.6	4.4	4.2
155	10.8	11.0		8.6	8.2	6.6	6.6	4.4	4.2
160	10.2	10.6		8.6	8.2	6.6	6.6	4.4	4.2
165	9.8	10.2		8.4	8.2	6.6	6.4	4.4	4.2
170	9.4	9.8		8.4	8.2	6.6	6.4	4.2	4.2
175	9.0	9.4		8.2	8.2	6.4	6.4	4.2	4.2
180	8.4	9.0		8.0	8.0	6.2	6.2	4.2	4.2
185	8.0	8.4		7.6	7.8	6.2	6.0	4.2	4.2
190	7.6	8.0		7.4	7.6	6.0	6.0	4.0	4.2
195	7.2	7.6		7.2	7.4	5.8	5.8	4.0	4.0
200	6.8	7.0		6.8	7.2	5.8	5.8	4.0	4.0
205	6.4			6.6	7.0	5.6	5.6	4.0	4.0
210	5.8			6.2	6.8	5.2	5.4	3.8	4.0
215	5.2			6.0	6.4	5.0	5.2	3.8	4.0
220	4.6			5.6	6.0	4.8	5.2	3.8	3.8
225	4.2			5.2	5.6	4.6	5.0	3.6	3.8
230	3.6			4.8		4.4	4.8	3.4	3.6
235	3.2			4.4		4.2	4.6	3.2	3.4
240	2.6			3.8		3.8	4.2	3.2	3.4
245		2.2		3.4		3.4	4.0	3.0	3.2
250				3.0		3.0		2.8	3.0
255				2.4		2.6		2.4	3.0
260								2.4	2.6

THIS CHART IS ONLY A GUIDE AND SHOULD NOT BE USED TO OPERATE THE CRANE. The individual crane's load chart, operating instructions and other instructional plates must be read and understood prior to operating the crane.

GMK6250-L

GROVE

load charts

12

												
Pounds (thousands)												
Feet	43 FT			72 FT			98 FT			125 FT		
	5°	20°	40°	5°	20°	40°	5°	20°	40°	5°	20°	40°
50	13.8											
55	13.8											
60	13.8	13.6		9.0								
65	13.8	13.6		9.0								
70	13.8	13.6		9.0			6.6					
75	13.8	13.6	13.6	9.0			6.6			4.4		
80	13.8	13.6	13.6	9.0	8.6		8.6			4.4		
85	13.8	13.6	13.6	9.0	8.6		6.6			4.4		
90	13.8	13.6	13.6	9.0	8.6		6.6	6.6		4.4		
95	13.8	13.6	13.6	9.0	8.6		6.6	6.6		4.4	4.4	
100	13.8	13.6	13.6	9.0	8.6	8.6	6.6	6.6		4.4	4.4	
105	13.8	13.6	13.6	9.0	8.6	8.6	6.6	6.6		4.4	4.4	
110	13.8	13.6	13.6	9.0	8.6	8.6	6.6	6.6		4.4	4.4	
115	13.8	13.6	13.6	9.0	8.6	8.6	6.6	6.6	6.6	4.4	4.4	
120	13.8	13.6	13.6	9.0	8.6	8.6	6.6	6.6	6.6	4.4	4.4	4.2
125	13.8	13.6	13.6	9.0	8.6	8.6	6.6	6.6	6.6	4.4	4.4	4.2
130	12.6	13.4	13.6	9.0	8.6	8.6	6.6	6.6	6.6	4.4	4.4	4.2
135	11.4	12.4	13.2	9.0	8.6	8.6	6.6	6.6	6.6	4.4	4.4	4.2
140	10.2	11.2	12.0	9.0	8.6	8.6	6.6	6.6	6.6	4.4	4.4	4.2
145	9.2	10.0	10.8	9.0	8.6	8.6	6.6	6.6	6.6	4.4	4.4	4.2
150	8.2	9.0	9.8	9.0	8.6	8.6	6.6	6.6	6.6	4.4	4.4	4.2
155	7.2	8.0	8.6	8.6	8.6	8.6	6.6	6.6	6.6	4.4	4.4	4.2
160	6.4	7.2	7.8	7.8	8.6	8.6	6.6	6.6	6.6	4.4	4.4	4.2
165	5.6	6.2	6.8	7.0	8.2	8.6	6.6	6.6	6.4	4.4	4.4	4.2
170	4.8	5.4	6.0	6.2	7.4	8.6	6.0	6.6	6.4	4.4	4.2	4.2
175	4.2	4.6	5.2	5.4	6.6	7.8	5.2	6.4	6.4	4.4	4.2	4.2
180	3.4	4.0	4.4	4.8	5.8	7.0	4.6	5.8	6.2	4.2	4.2	4.2
185	2.8	3.2	3.6	4.0	5.2	6.2	3.8	5.0	6.0	3.6	4.2	4.2
190	2.2	2.6	3.0	3.4	4.4	5.4	3.2	4.4	5.4	3.0	4.0	4.2
195			2.4	2.8	3.8	4.6	2.6	3.8	4.6	2.4	3.4	4.0
200				2.2	3.2	4.0		3.0	4.0		2.8	3.8
205					2.6	3.4		2.6	3.4		2.2	3.2
210						2.8			2.8			2.6
215									2.2			

												
Pounds (thousands)												
Feet	43 FT		72 FT				98 FT				125 FT	
	5°-20°	20°-40°	5°-20°	20°-40°		5°-20°	20°-40°		5°-20°	20°-40°		
55												
60	13.2											
65	13.2											
70	13.2											
75	13.2	13.6										
80	13.2	13.6		8.6								
85	13.2	13.6		8.6								
90	13.2	13.6		8.6			6.6					
95	13.2	13.6		8.6			6.6			4.4		
100	13.2	13.6		8.6	8.2		6.6			4.4		
105	13.2	13.6		8.6	8.2		6.6			4.4		
110	13.2	13.6		8.6	8.2		6.6			4.4		
115	13.2	13.6		8.6	8.2		6.6	6.6		4.4		
120	13.2	13.6		8.6	8.2		6.6	6.6		4.4	4.2	
125	13.2	13.4		8.6	8.2		6.6	6.6		4.4	4.2	
130	12.6	13.0		8.6	8.2		6.6	6.6		4.4	4.2	
135	11.4	12.6		8.6	8.2		6.6	6.6		4.4	4.2	
140	10.2	11.8		8.6	8.2		6.6	6.6		4.4	4.2	
145	9.2	10.8		8.6	8.2		6.6	6.6		4.4	4.2	
150	8.2	9.8		8.6	8.2		6.6	6.6		4.4	4.2	
155	7.2	8.8		8.6	8.2		6.6	6.6		4.4	4.2	
160	6.4	7.8		7.8	8.2		6.6	6.6		4.4	4.2	
165	5.6	6.8		7.0	8.2		6.6	6.4		4.4	4.2	
170	4.8	6.0		6.2	7.4		6.0	6.4		4.2	4.2	
175	4.2	5.2		5.4	6.6		5.2	6.4		4.2	4.2	
180	3.4	4.4		4.8	5.8		4.6	5.8		4.2	4.2	
185	2.8	3.8		4.0	5.2		3.8	5.0		3.6	4.2	
190		3.2		3.4	4.4		3.2	4.4		3.0	4.0	
195		2.4		2.8	3.8		2.6	3.8		2.4	3.4	
200				2.2	3.2			3.0			2.8	
205					2.6			2.6			2.2	

GMK6250-L

boom extension configurations

13

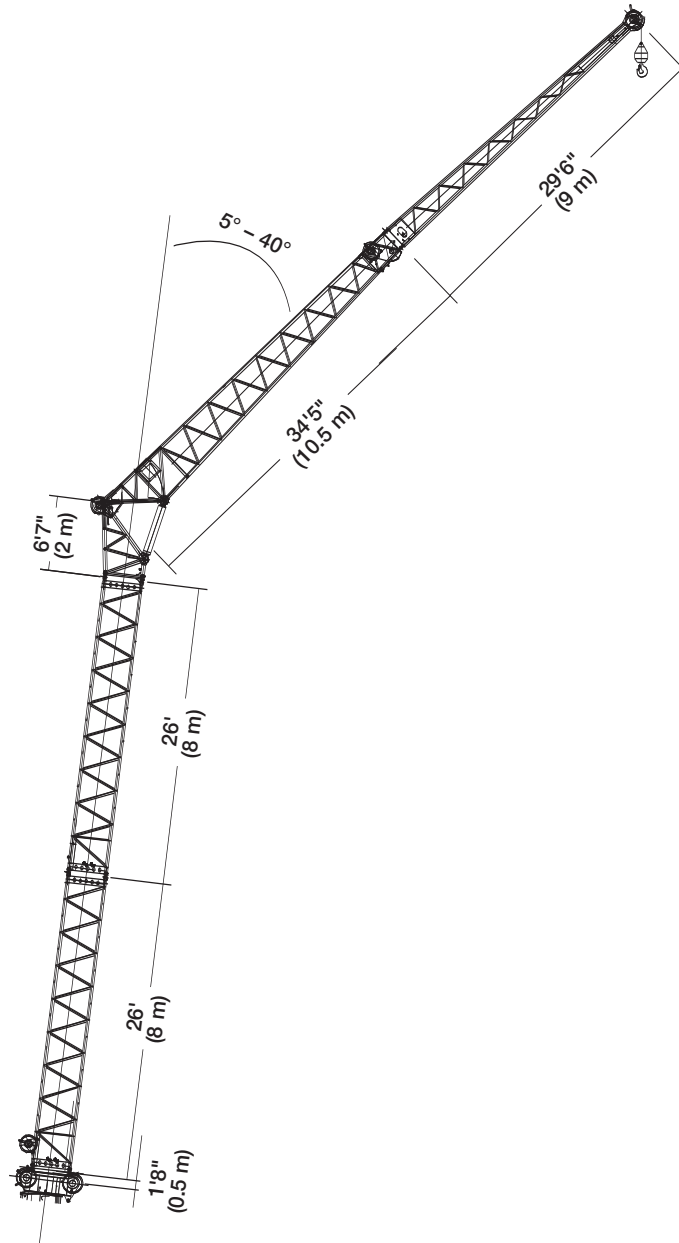

Length (ft.)	Intermediate section boom extension make-up			
	26' (8 m)	6'7" (2 m)	34'5" (10.5 m)	29'6" (9 m)
43	—	1x	1x	—
72	—	1x	1x	1x
98	1x	1x	1x	1x
125	2x	1x	1x	1x

THIS CHART IS ONLY A GUIDE AND SHOULD NOT BE USED TO OPERATE THE CRANE. The individual crane's load chart, operating instructions and other instructional plates must be read and understood prior to operating the crane.

GMK6250-L

GROVE

rated lifting capacities

14

IMPORTANT NOTES:

WARNING: THIS CHART IS ONLY A GUIDE.

The notes below are for illustration only and should not be relied upon to operate the crane. The individual crane's load chart, operating instructions and other instruction plates must be read and understood prior to operating the crane.

1. All rated loads up to 420,000 pounds meet ANSI/ASME B30.5, Mobile and Locomotive Cranes. Testing and development were performed to SAEJ1063, Cantilevered Boom Crane Structures - Method of Test and SAEJ765 Crane Stability Test Code.

2. Capacities given do not include the weight of hook blocks, slings, auxiliary lifting equipment and load handling devices. Their weights must be added to the load to be lifted. When more than minimum required reeving is used, the additional rope weight shall be considered part of the load.

3. The machine shall be leveled on a firm supporting surface. Depending on the nature of the supporting surface, it may be necessary to have structural supports under the outrigger floats to spread the load to a larger bearing surface.

4. When either boom length or radius or both are between values listed, the smallest load shown at either the next larger radius or next longer or shorter boom length shall be used.

5. For outrigger operation, outriggers shall be properly extended with tires raised off the ground before operating the boom or lifting loads.

† Comparative Rating

A rating designation based upon the premise that large capacity European cranes are typically purchased and used as long boom, high reach, long radius lift cranes, not as heavy lift cranes.

To provide a GMK 6250-L crane with the necessary equipment to achieve maximum lift capacity will drastically reduce long boom performance. Therefore, augmenting lifting equipment is required for buyers who require such capacities.

Symbols Glossary

	Frame		Steering
	Outriggers		Transmission
	Outrigger Controls		Axles
	Engine		Brakes
	Fuel Tank Capacity		Tires
	Electrical System		Suspension
	Drive		Rotation
	Lights		Boom Elevation
	Cab		Swing
	Boom		Counterweight
	Fixed Swingaway		Oil
	Tele-Swingaway		Hydraulic System
	Lattice Extension (Luffing)		Hoist
	Boom Nose		Radius
	Boom Extension		Boom Length
	Speed		Hookblock
	Grade		Gear
	Lattice Extension		Luffing Jib

GMK6250-L

GROVE

Regional Headquarters

Americas

Manitowoc, Wisconsin, USA

Tel: +1 920 684 6621

Fax: +1 920 683 6278

Shady Grove, Pennsylvania, USA

Tel: +1 717 597 8121

Fax: +1 717 597 4062

Regional Offices

Americas

Brazil

Alphaville

Tel: +55 11 4688 2716

Fax: +55 11 4191 1471

Mexico

Monterrey

Tel: +52 81 8124 0128

Fax: +52 81 8124 0129

Europe, Middle East, Africa

Algeria

Hydra

Tel: +21 3 21 48 1173

Fax: +21 3 21 48 1454

Czech Republic

Netvorice

Tel: +420 317 78 9313

Fax: +420 317 78 9314

France

Baudemont

Tel: +33 385 28 2589

Fax: +33 385 28 0430

Cergy

Tel: +33 130 31 3150

Fax: +33 130 38 6085

Decines

Tel: +33 472 81 5000

Fax: +33 472 81 5010

Germany

Langenfeld

Tel: +49 21 73 8909-0

Fax: +49 21 73 8909 30

Hungary

Budapest

Tel: +36 13 39 8622

Fax: +36 13 39 8622

Italy

Parabiago

Tel: +390 331 49 3311

Fax: +390 331 49 3330

Europe, Middle East, Africa

Ecully, France

Tel: +33 472 18 2020

Fax: +33 472 18 2000

Netherlands

Breda

Tel: +31 76 578 3999

Fax: +31 76 578 3978

Poland

Warsaw

Tel: +48 22 843 3824

Fax: +48 22 843 3471

Portugal

Alfena

Tel: +351 229 69 8840

Fax: +351 229 69 8848

Lisbon

Tel: +351 212 109 340

Fax: +351 212 109 349

Russia

Moscow

Tel: +7 495 641 2359

Fax: +7 495 641 2358

U.A.E.

Dubai

Tel: +971 4 3381 861

Fax: +971 4 3382 343

U. K.

Middlesex

Tel: +44 1 895 43 0053

Fax: +44 1 895 45 9500

Sunderland

Tel: +44 191 522 2000

Fax: +44 191 522 2052

Asia – Pacific

Australia

Melbourne

Tel: +61 3 9 336 1300

Fax: +61 3 9 336 1322

Sydney

Tel: +61 2 9 896 4433

Fax: +61 2 9 896 3122

Asia – Pacific

Shanghai, China

Tel: +86 21 51113579

Fax: +86 21 51113578

Singapore

Tel: +65 6264 1188

Fax: +65 6862 4142

China

Beijing

Tel: +86 21 58674761

Fax: +86 21 58674760

Xi'an

Tel: +86 29 87891465

Fax: +86 29 87884504

Korea

Seoul

Tel: +82 2 508 3361

Fax: +82 2 508 3365

Philippines

Makati City

Tel: +63 2 844 9437

Fax: +63 2 844 4712

Factories

U.S.A.

Manitowoc

Shady Grove

Brazil

Alphaville

France

Charlieu

La Clayette

Moulins

India

Calcutta

Puna

Italy

Niella Tanaro

Germany

Wilhelmshaven

Portugal

Fânzeres

China

Zhangjiagang

